

Lecture 2:

Image Classification with Linear Classifiers

Administrative: Assignment 1

Out tomorrow, Due 4/21 11:59pm

- K-Nearest Neighbor
- Linear classifiers: SVM, Softmax
- Two-layer neural network
- Image features

Administrative: Course Project

Project proposal due 4/24 (Monday) 11:59pm

Contact your assigned TA for initial guidance (Canvas -> People -> Groups)

Use Google Form to find project partners (will be posted later today)

“Is X a valid project for 231n?” --- Ed private post / TA Office Hours

More info on the website

Administrative: Discussion Sections

This Friday 1:30pm-2:20 pm, in person at Thornton 102, remote on Zoom
(recording will be made available)

Python / Numpy, Google Colab

Presenter: Manasi Sharma (TA)

Syllabus

Deep Learning Basics

Data-driven approaches
Linear classification & kNN
Loss functions
Optimization
Backpropagation
Multi-layer perceptrons
Neural Networks

Convolutional Neural Networks

Convolutions
PyTorch / TensorFlow
Activation functions
Batch normalization
Transfer learning
Data augmentation
Momentum / RMSProp / Adam
Architecture design

Computer Vision Applications

RNNs / Attention / Transformers
Image captioning
Object detection and segmentation
Style transfer
Video understanding
Generative models
Self-supervised learning
3D vision
Robot learning
Human-centered AI
Fairness & ethics

Image Classification

A Core Task in Computer Vision

Today:

- The image classification task
- Two basic data-driven approaches to image classification
 - K-nearest neighbor and linear classifier

Image Classification: A core task in Computer Vision



This image by [Nikita](#) is licensed under [CC-BY 2.0](#)

(assume given a set of possible labels)
{dog, cat, truck, plane, ...}

→ cat

The Problem: Semantic Gap

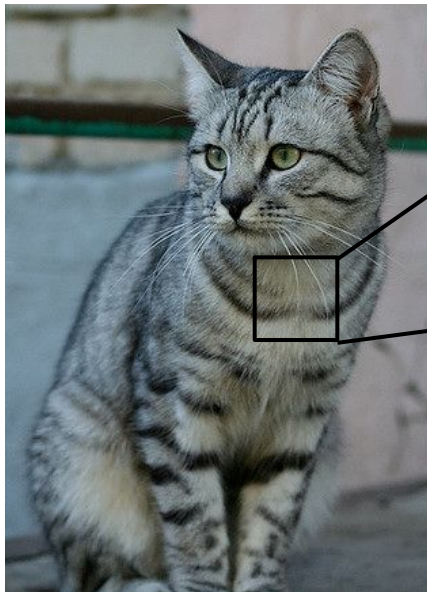

This image by [Nikita](#) is licensed under [CC-BY 2.0](#)

```
[[105 112 108 111 104 99 106 99 96 103 112 119 104 97 93 87]
 [ 91 98 102 106 104 79 98 103 99 105 123 136 110 105 94 85]
 [ 76 85 90 105 128 105 87 96 95 99 115 112 106 103 99 85]
 [ 99 81 81 93 120 131 127 100 95 98 102 99 96 93 101 94]
 [106 91 61 64 69 91 88 85 101 107 109 98 75 84 96 95]
 [114 108 85 55 55 69 64 54 64 87 112 129 98 74 84 91]
 [133 137 147 103 65 81 80 65 52 54 74 84 102 93 85 82]
 [128 137 144 140 109 95 86 70 62 65 63 60 73 86 101]
 [125 133 148 137 119 121 117 94 65 79 80 65 54 64 72 98]
 [127 125 131 147 133 127 126 131 111 96 89 75 61 64 72 84]
 [115 114 109 123 150 148 131 118 113 109 100 92 74 65 72 78]
 [ 89 93 90 97 108 147 131 118 113 114 113 109 106 95 77 80]
 [ 63 77 86 81 77 79 102 123 117 115 117 125 125 130 115 87]
 [ 62 65 82 89 78 71 80 101 124 126 119 101 107 114 131 119]
 [ 63 65 75 88 89 71 62 81 120 138 135 105 81 98 110 118]
 [ 87 65 71 87 106 95 69 45 76 130 126 107 92 94 105 112]
 [118 97 82 86 117 123 116 66 41 51 95 93 89 95 102 107]
 [164 146 112 80 82 120 124 104 76 48 45 66 88 101 102 109]
 [157 170 157 120 93 86 114 132 112 97 69 55 70 82 99 94]
 [130 128 134 161 139 100 109 118 121 134 114 87 65 53 69 86]
 [128 112 96 117 150 144 120 115 104 107 102 93 87 81 72 79]
 [123 107 96 86 83 112 153 149 122 109 104 75 80 107 112 99]
 [122 121 102 80 82 86 94 117 145 148 153 102 58 78 92 107]
 [122 164 148 103 71 56 78 83 93 103 119 139 102 61 69 84]]
```

What the computer sees

An image is a tensor of integers between [0, 255]:

e.g. 800 x 600 x 3
(3 channels RGB)

Challenges: Viewpoint variation

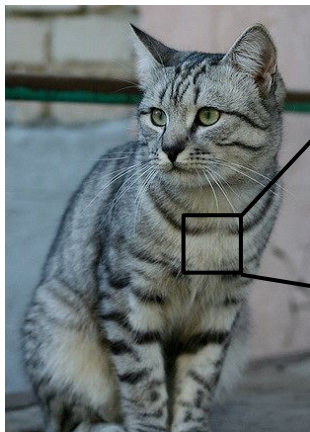
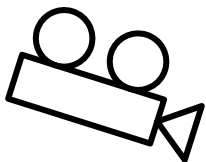

[1185	112	188	111	184	99	106	99	96	103	112	119	184	97	93	87]
[91	98	182	186	184	79	98	183	99	185	123	136	118	185	94	85]
[76	85	98	185	128	185	87	96	95	98	115	112	196	183	99	85]
[99	81	81	93	120	131	127	100	95	98	182	99	96	93	181	94]
[186	91	61	64	69	91	88	85	181	187	189	98	75	84	96	95]
[114	188	85	55	69	64	54	64	87	112	129	98	74	84	91]	
[133	137	147	183	65	81	80	65	52	54	74	84	182	93	85	82]
[128	137	144	140	189	95	86	78	62	65	63	63	68	73	86	181]
[125	133	148	137	119	121	117	94	65	79	88	65	64	72	98]	
[127	125	131	147	133	127	126	131	111	96	89	75	61	64	72	84]
[115	114	189	123	158	148	131	118	113	189	188	92	74	65	72	78]
[89	93	98	97	188	147	131	118	113	114	113	189	186	95	77	88]
[63	77	86	81	77	79	182	123	117	115	117	125	125	138	115	87]
[62	65	82	89	78	71	80	181	124	126	119	181	187	114	131	119]
[63	65	75	88	89	71	62	81	128	138	135	185	61	98	118	118]
[87	65	71	87	186	95	69	45	76	138	126	187	92	94	185	112]
[118	97	82	86	117	123	116	66	41	51	95	93	89	95	182	187]
[164	146	112	88	82	128	124	184	76	48	45	66	88	181	182	189]
[157	178	157	128	83	86	114	132	112	97	69	55	78	82	98	94]
[138	128	134	161	139	188	189	118	121	134	114	87	65	53	69	86]
[1128	112	96	117	158	144	128	115	184	187	182	93	87	81	72	79]
[123	187	96	86	83	112	153	149	122	189	184	75	88	187	112	99]
[122	121	182	88	82	86	94	117	145	148	153	182	58	78	92	187]
[122	164	148	183	71	56	78	83	93	183	119	139	182	61	69	84]

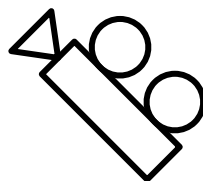
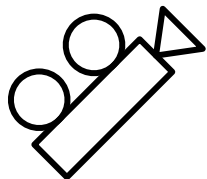

All pixels change when the camera moves!

This image by Nikita is licensed under [CC-BY 2.0](https://creativecommons.org/licenses/by/2.0/)

Challenges: Illumination



[This image](#) is [CC0 1.0](#) public domain

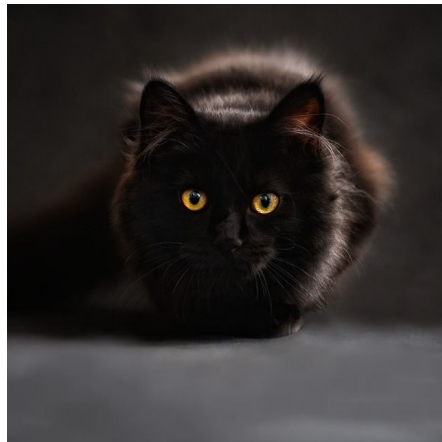

[This image](#) is [CC0 1.0](#) public domain



[This image](#) is [CC0 1.0](#) public domain

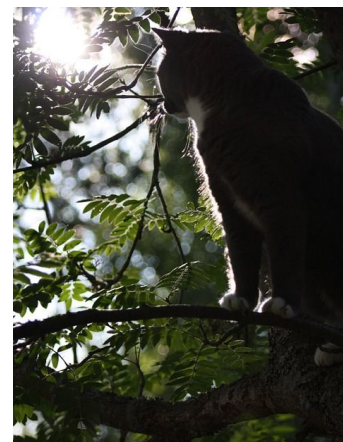

[This image](#) is [CC0 1.0](#) public domain

Challenges: Background Clutter



[This image](#) is [CC0 1.0](#) public domain



[This image](#) is [CC0 1.0](#) public domain

Challenges: Occlusion



[This image](#) is [CC0 1.0](#) public domain



[This image](#) is [CC0 1.0](#) public domain



[This image](#) by [jonsso](#) is licensed under [CC-BY 2.0](#)

Challenges: Deformation

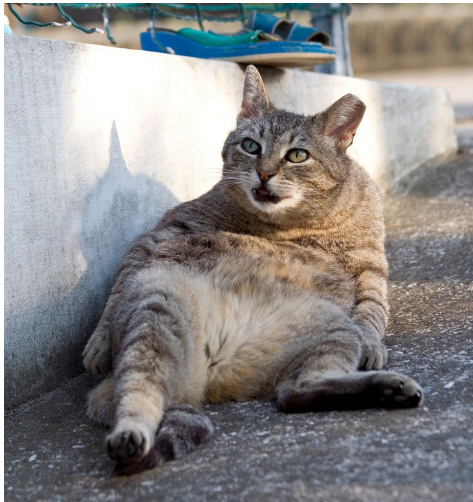

This image by [Umberto Salvagnin](#) is licensed under [CC-BY 2.0](#)



This image by [Umberto Salvagnin](#) is licensed under [CC-BY 2.0](#)



This image by [sare bear](#) is licensed under [CC-BY 2.0](#)

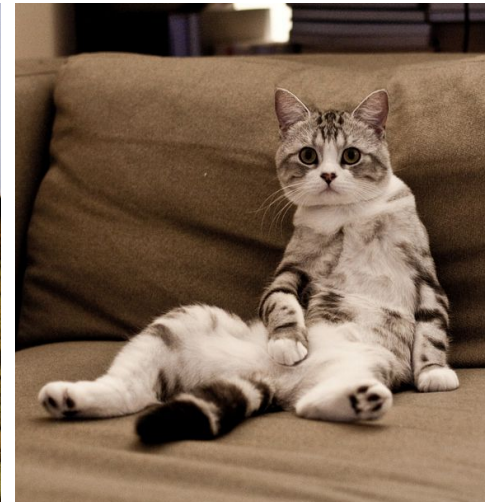

This image by [Tom Thai](#) is licensed under [CC-BY 2.0](#)

Challenges: Intraclass variation



[This image](#) is [CC0 1.0](#) public domain

Challenges: Context

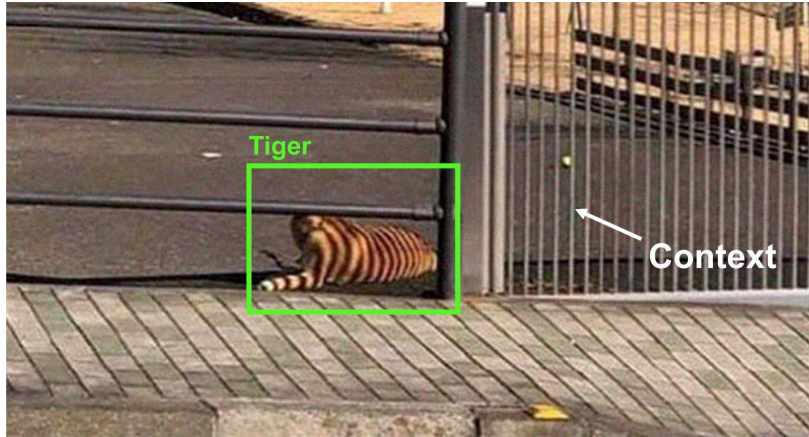
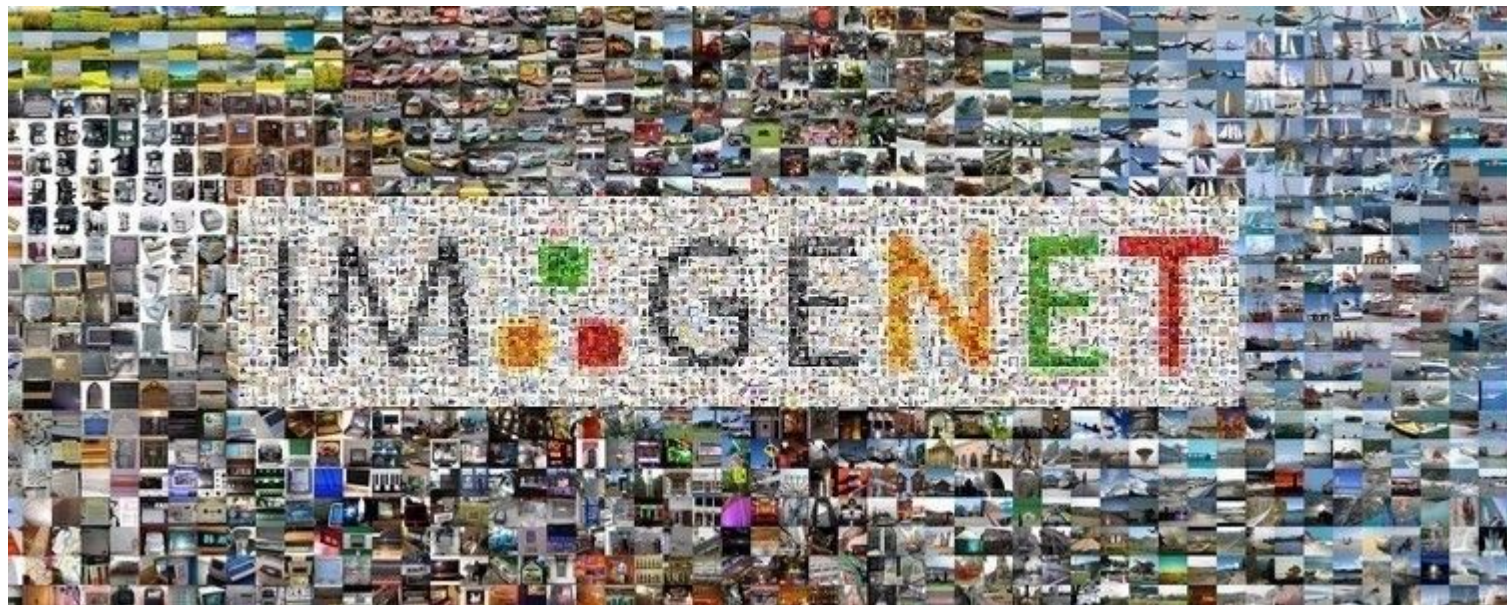

Image source:

https://www.linkedin.com/posts/ralph-aboujaoude-diaz-40838313_technology-artificialintelligence-computervision-activity-6912446088364875776-h-lq?utm_source=linkedin_share&utm_medium=member_desktop_web

Modern computer vision algorithms



[This image](#) is [CC0 1.0](#) public domain

An image classifier

```
def classify_image(image):  
    # Some magic here?  
    return class_label
```

Unlike e.g. sorting a list of numbers,

no obvious way to hard-code the algorithm for recognizing a cat, or other classes.

Attempts have been made



Find edges



Find corners

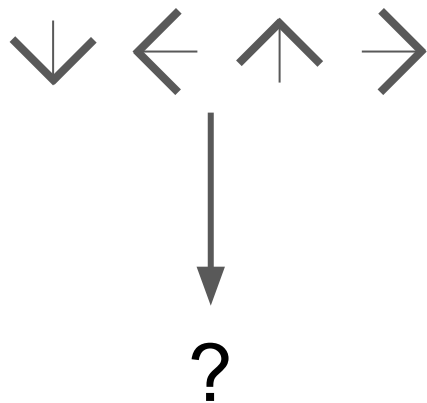

John Canny, "A Computational Approach to Edge Detection", IEEE TPAMI 1986

Machine Learning: Data-Driven Approach

1. Collect a dataset of images and labels
2. Use Machine Learning algorithms to train a classifier
3. Evaluate the classifier on new images

Example training set

```
def train(images, labels):  
    # Machine learning!  
    return model
```

```
def predict(model, test_images):  
    # Use model to predict labels  
    return test_labels
```

airplane

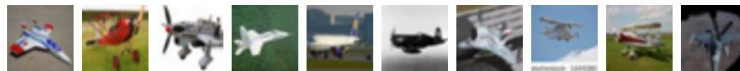

automobile



bird



cat

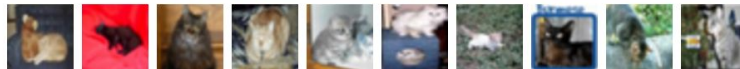

deer

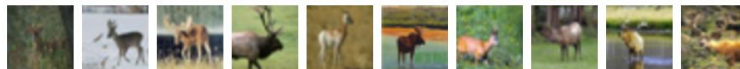

Nearest Neighbor Classifier

First classifier: Nearest Neighbor

```
def train(images, labels):  
    # Machine learning!  
    return model
```



Memorize all
data and labels

```
def predict(model, test_images):  
    # Use model to predict labels  
    return test_labels
```



Predict the label
of the most similar
training image

First classifier: Nearest Neighbor



Training data with labels



query data

Distance Metric $\left| \begin{array}{c} \text{query cat} \\ \text{training cat} \end{array} \right| \rightarrow \mathbb{R}$



Distance Metric to compare images

L1 distance:
$$d_1(I_1, I_2) = \sum_P |I_1^P - I_2^P|$$

test image		training image		pixel-wise absolute value differences				
56	32	10	18	46	12	14	1	= $\xrightarrow{\text{add}}$ 456
90	23	128	133	82	13	39	33	
24	26	178	200	12	10	0	30	
2	0	255	220	2	32	22	108	

Nearest Neighbor classifier

```
import numpy as np

class NearestNeighbor:
    def __init__(self):
        pass

    def train(self, X, y):
        """ X is N x D where each row is an example. Y is 1-dimension of size N """
        # the nearest neighbor classifier simply remembers all the training data
        self.Xtr = X
        self.ytr = y

    def predict(self, X):
        """ X is N x D where each row is an example we wish to predict label for """
        num_test = X.shape[0]
        # lets make sure that the output type matches the input type
        Ypred = np.zeros(num_test, dtype = self.ytr.dtype)

        # loop over all test rows
        for i in xrange(num_test):
            # find the nearest training image to the i'th test image
            # using the L1 distance (sum of absolute value differences)
            distances = np.sum(np.abs(self.Xtr - X[i,:]), axis = 1)
            min_index = np.argmin(distances) # get the index with smallest distance
            Ypred[i] = self.ytr[min_index] # predict the label of the nearest example

        return Ypred
```

Nearest Neighbor classifier

```
import numpy as np
```

```
class NearestNeighbor:
```

```
    def __init__(self):
```

```
        pass
```

```
    def train(self, X, y):
```

```
        """ X is N x D where each row is an example. Y is 1-dimension of size N """
```

```
        # the nearest neighbor classifier simply remembers all the training data
```

```
        self.Xtr = X
```

```
        self.ytr = y
```

```
    def predict(self, X):
```

```
        """ X is N x D where each row is an example we wish to predict label for """
```

```
        num_test = X.shape[0]
```

```
        # lets make sure that the output type matches the input type
```

```
        Ypred = np.zeros(num_test, dtype = self.ytr.dtype)
```

```
        # loop over all test rows
```

```
        for i in xrange(num_test):
```

```
            # find the nearest training image to the i'th test image
```

```
            # using the L1 distance (sum of absolute value differences)
```

```
            distances = np.sum(np.abs(self.Xtr - X[i,:]), axis = 1)
```

```
            min_index = np.argmin(distances) # get the index with smallest distance
```

```
            Ypred[i] = self.ytr[min_index] # predict the label of the nearest example
```

```
        return Ypred
```

Memorize training data

Nearest Neighbor classifier

```
import numpy as np

class NearestNeighbor:
    def __init__(self):
        pass

    def train(self, X, y):
        """ X is N x D where each row is an example. Y is 1-dimension of size N """
        # the nearest neighbor classifier simply remembers all the training data
        self.Xtr = X
        self.ytr = y

    def predict(self, X):
        """ X is N x D where each row is an example we wish to predict label for """
        num_test = X.shape[0]
        # lets make sure that the output type matches the input type
        Ypred = np.zeros(num_test, dtype = self.ytr.dtype)

        # loop over all test rows
        for i in xrange(num_test):
            # find the nearest training image to the i'th test image
            # using the L1 distance (sum of absolute value differences)
            distances = np.sum(np.abs(self.Xtr - X[i,:]), axis = 1)
            min_index = np.argmin(distances) # get the index with smallest distance
            Ypred[i] = self.ytr[min_index] # predict the label of the nearest example

        return Ypred
```

For each test image:
Find closest train image
Predict label of nearest image

```

import numpy as np

class NearestNeighbor:
    def __init__(self):
        pass

    def train(self, X, y):
        """ X is N x D where each row is an example. Y is 1-dimension of size N """
        # the nearest neighbor classifier simply remembers all the training data
        self.Xtr = X
        self.ytr = y

    def predict(self, X):
        """ X is N x D where each row is an example we wish to predict label for """
        num_test = X.shape[0]
        # lets make sure that the output type matches the input type
        Ypred = np.zeros(num_test, dtype = self.ytr.dtype)

        # loop over all test rows
        for i in xrange(num_test):
            # find the nearest training image to the i'th test image
            # using the L1 distance (sum of absolute value differences)
            distances = np.sum(np.abs(self.Xtr - X[i,:]), axis = 1)
            min_index = np.argmin(distances) # get the index with smallest distance
            Ypred[i] = self.ytr[min_index] # predict the label of the nearest example

        return Ypred

```

Nearest Neighbor classifier

Q: With N examples, how fast are training and prediction?

Ans: Train $O(1)$,
predict $O(N)$

This is bad: we want classifiers that are **fast** at prediction; **slow** for training is ok

```

import numpy as np

class NearestNeighbor:
    def __init__(self):
        pass

    def train(self, X, y):
        """ X is N x D where each row is an example. Y is 1-dimension of size N """
        # the nearest neighbor classifier simply remembers all the training data
        self.Xtr = X
        self.ytr = y

    def predict(self, X):
        """ X is N x D where each row is an example we wish to predict label for """
        num_test = X.shape[0]
        # lets make sure that the output type matches the input type
        Ypred = np.zeros(num_test, dtype = self.ytr.dtype)

        # loop over all test rows
        for i in xrange(num_test):
            # find the nearest training image to the i'th test image
            # using the L1 distance (sum of absolute value differences)
            distances = np.sum(np.abs(self.Xtr - X[i,:]), axis = 1)
            min_index = np.argmin(distances) # get the index with smallest distance
            Ypred[i] = self.ytr[min_index] # predict the label of the nearest example

        return Ypred

```

Nearest Neighbor classifier

Many methods exist for fast / approximate nearest neighbor (beyond the scope of 231N!)

A good implementation:

<https://github.com/facebookresearch/faiss>

Johnson et al, "Billion-scale similarity search with GPUs", arXiv 2017

What does this look like?

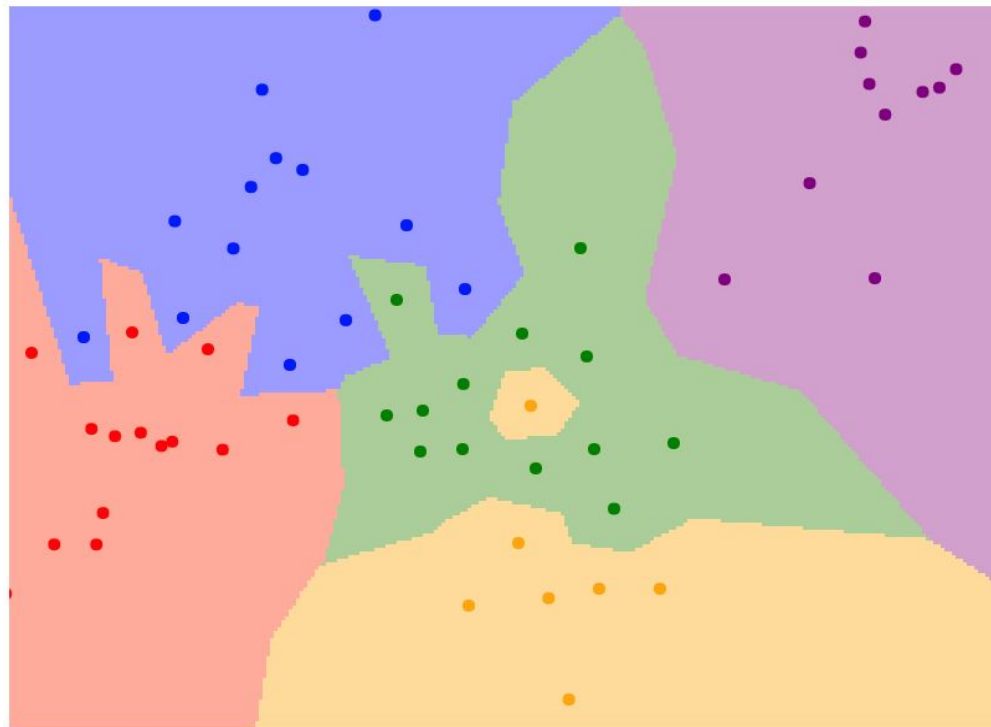

1-nearest neighbor

K-Nearest Neighbors

Instead of copying label from nearest neighbor,
take **majority vote** from K closest points

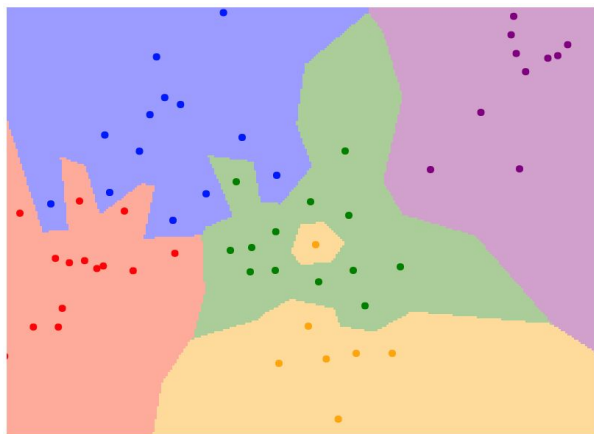

$K = 1$

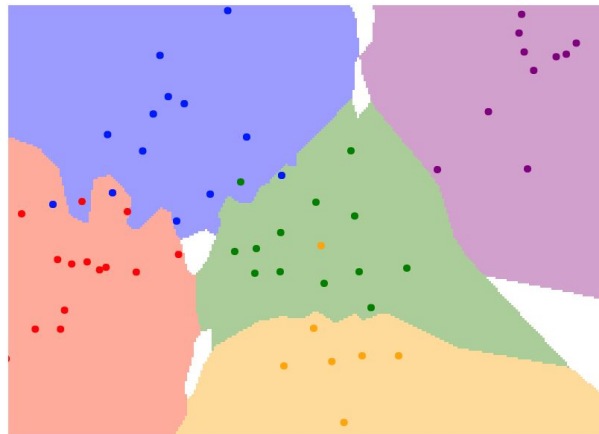

$K = 3$

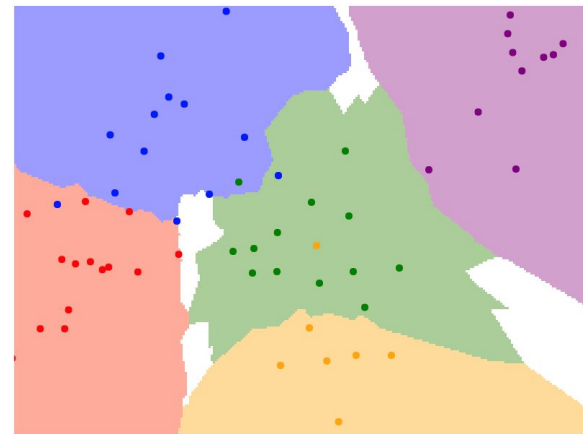

$K = 5$

K-Nearest Neighbors: Distance Metric

L1 (Manhattan) distance

$$d_1(I_1, I_2) = \sum_p |I_1^p - I_2^p|$$

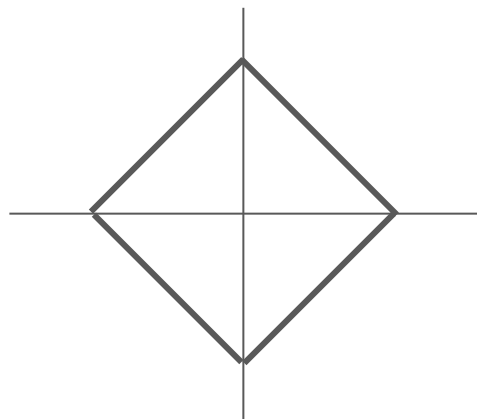

L2 (Euclidean) distance

$$d_2(I_1, I_2) = \sqrt{\sum_p (I_1^p - I_2^p)^2}$$

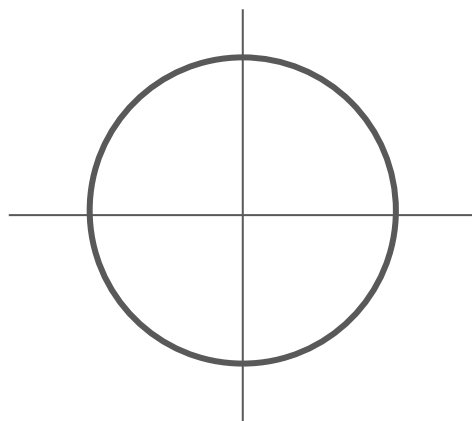

K-Nearest Neighbors: Distance Metric

L1 (Manhattan) distance

$$d_1(I_1, I_2) = \sum_p |I_1^p - I_2^p|$$

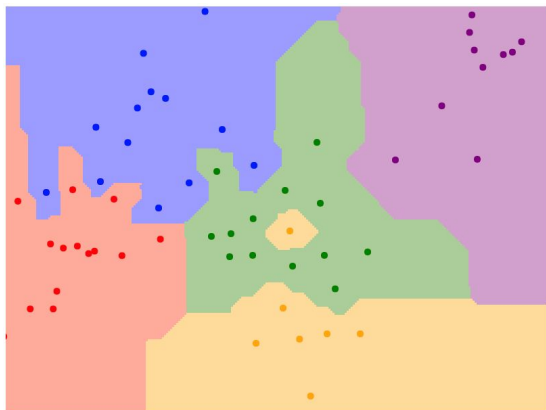

K = 1

L2 (Euclidean) distance

$$d_2(I_1, I_2) = \sqrt{\sum_p (I_1^p - I_2^p)^2}$$

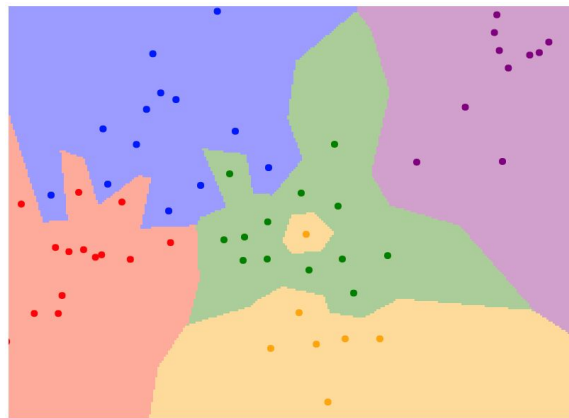

K = 1

K-Nearest Neighbors: try it yourself!

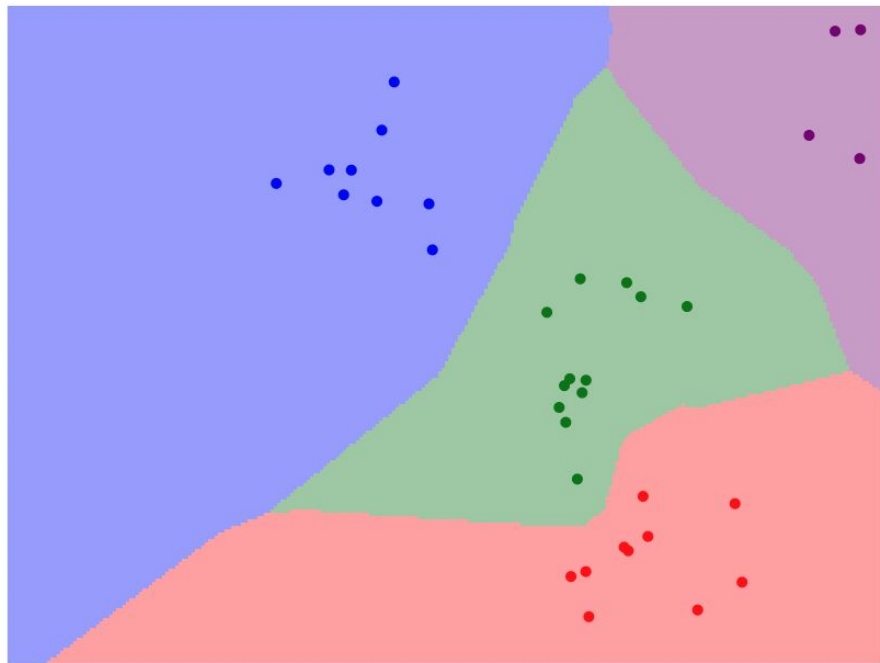

<http://vision.stanford.edu/teaching/cs231n-demos/knn/>

Hyperparameters

What is the best value of **k** to use?

What is the best **distance** to use?

These are **hyperparameters**: choices about the algorithms themselves.

Very problem/dataset-dependent.

Must try them all out and see what works best.

Setting Hyperparameters

Idea #1: Choose hyperparameters that work best on the **training data**



train

Setting Hyperparameters

Idea #1: Choose hyperparameters that work best on the **training data**

BAD: $K = 1$ always works perfectly on training data



train

Setting Hyperparameters

Idea #1: Choose hyperparameters that work best on the **training data**

BAD: $K = 1$ always works perfectly on training data



train

Idea #2: choose hyperparameters that work best on **test** data



train

test

Setting Hyperparameters

Idea #1: Choose hyperparameters that work best on the **training data**

BAD: $K = 1$ always works perfectly on training data



train

Idea #2: choose hyperparameters that work best on **test** data

BAD: No idea how algorithm will perform on new data



train



test

Never do this!

Setting Hyperparameters

Idea #1: Choose hyperparameters that work best on the **training data**

BAD: $K = 1$ always works perfectly on training data



train

Idea #2: choose hyperparameters that work best on **test** data

BAD: No idea how algorithm will perform on new data



train

test

Idea #3: Split data into **train, val**; choose hyperparameters on val and evaluate on test

Better!



train

validation

test

Setting Hyperparameters

train

Idea #4: Cross-Validation: Split data into **folds**, try each fold as validation and average the results

fold 1	fold 2	fold 3	fold 4	fold 5	test
fold 1	fold 2	fold 3	fold 4	fold 5	test
fold 1	fold 2	fold 3	fold 4	fold 5	test

Useful for small datasets, but not used too frequently in deep learning

Example Dataset: CIFAR10

10 classes

50,000 training images

10,000 testing images

airplane



automobile



bird

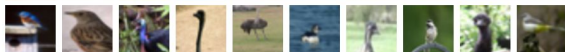

cat



deer

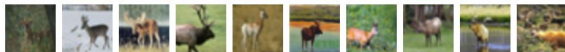

dog



frog

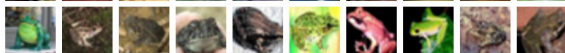

horse

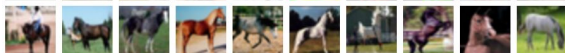

ship



truck



Alex Krizhevsky, "Learning Multiple Layers of Features from Tiny Images", Technical Report, 2009.

Example Dataset: CIFAR10

10 classes

50,000 training images

10,000 testing images

airplane



automobile



bird



cat



deer



dog



frog



horse



ship



truck



Test images and nearest neighbors

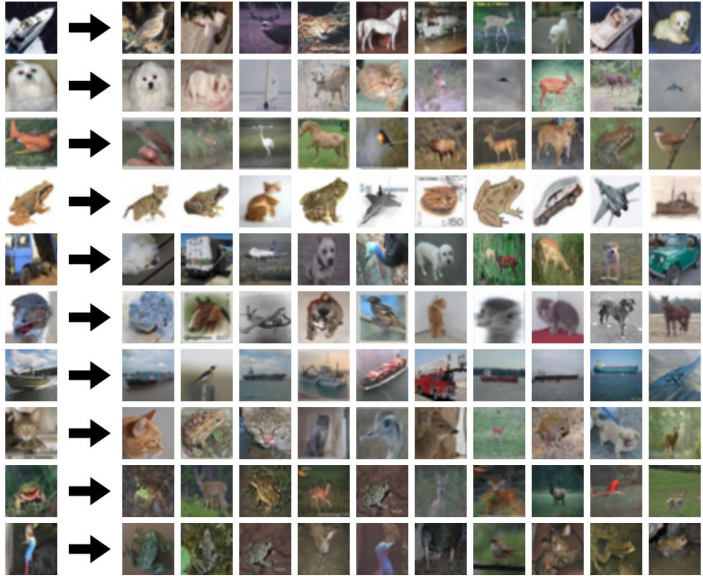

Alex Krizhevsky, "Learning Multiple Layers of Features from Tiny Images", Technical Report, 2009.

Setting Hyperparameters

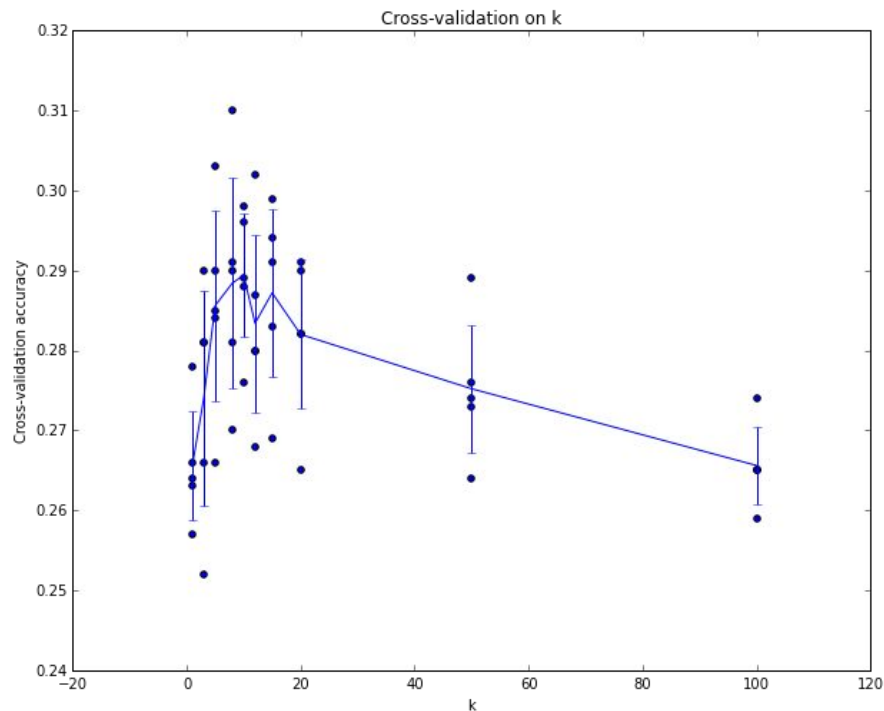

Example of
5-fold cross-validation
for the value of k .

Each point: single
outcome.

The line goes
through the mean, bars
indicated standard
deviation

(Seems that $k \approx 7$ works best
for this data)

What does this look like?



What does this look like?



k-Nearest Neighbor with pixel distance **never used**.

- Distance metrics on pixels are not informative

[Original image is CC0 public domain](#)

Original



Occluded



Shifted (1 pixel)



Tinted



(All three images on the right have the same pixel distances to the one on the left)

k-Nearest Neighbor with pixel distance **never used**.

- Curse of dimensionality

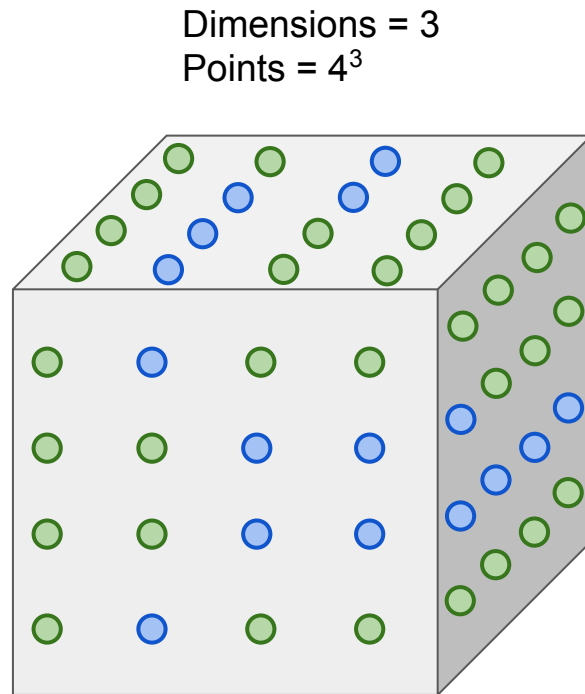
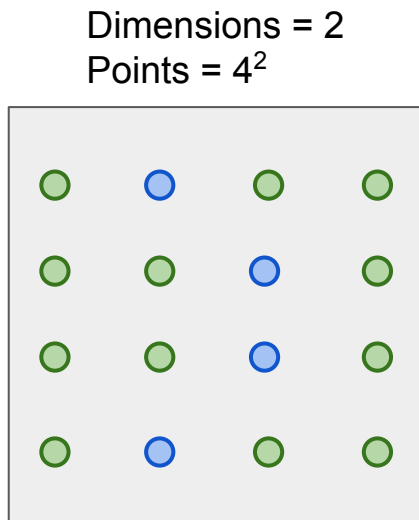
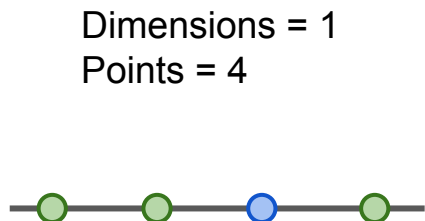

K-Nearest Neighbors: Summary

In **image classification** we start with a **training set** of images and labels, and must predict labels on the **test set**

The **K-Nearest Neighbors** classifier predicts labels based on the K nearest training examples

Distance metric and K are **hyperparameters**

Choose hyperparameters using the **validation set**

Only run on the test set once at the very end!

Linear Classifier

Parametric Approach

Image



Array of **32x32x3** numbers
(3072 numbers total)

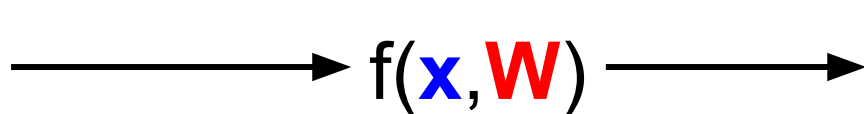

10 numbers giving
class scores



W

parameters
or weights

Parametric Approach: Linear Classifier

Image



Array of **32x32x3** numbers
(3072 numbers total)

$$f(x, W) = Wx$$

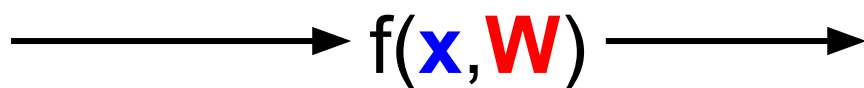

10 numbers giving
class scores



W

parameters
or weights

Parametric Approach: Linear Classifier

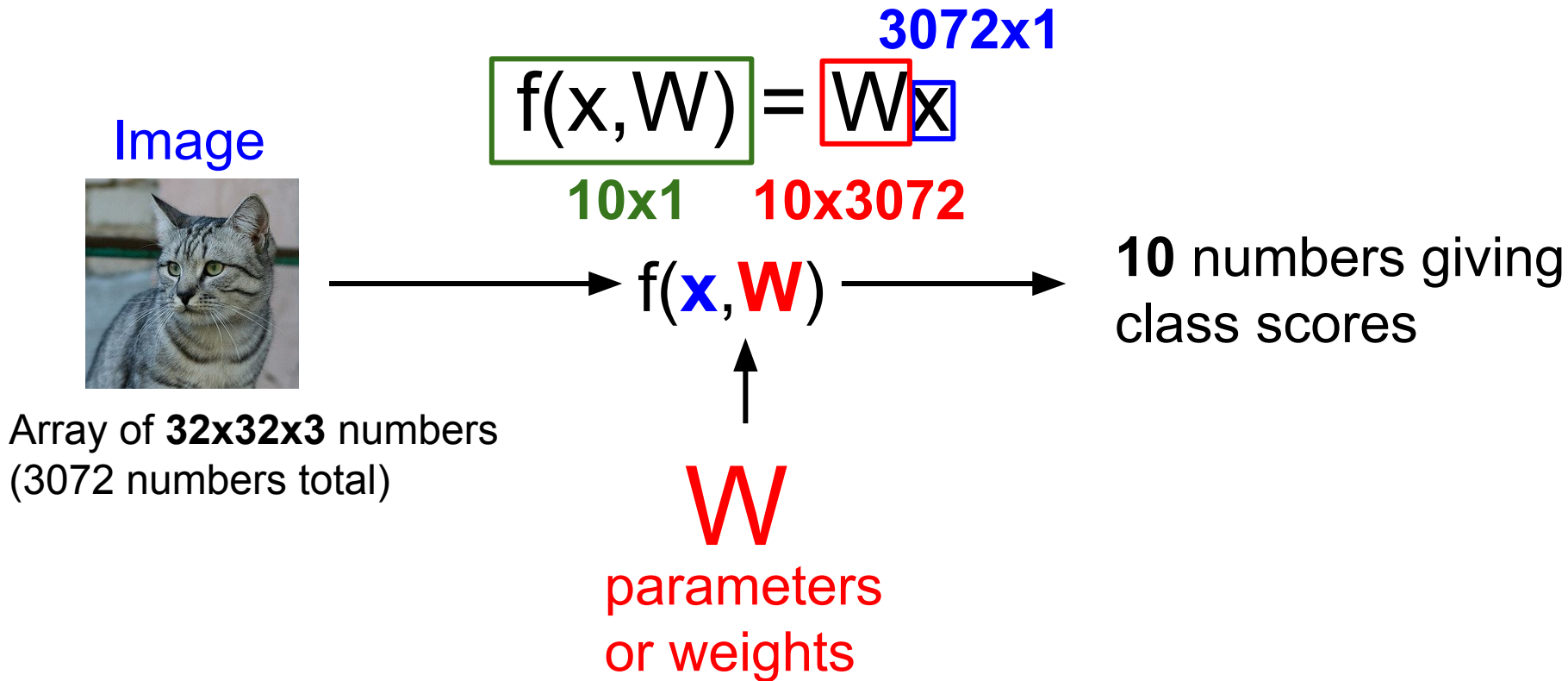

Parametric Approach: Linear Classifier

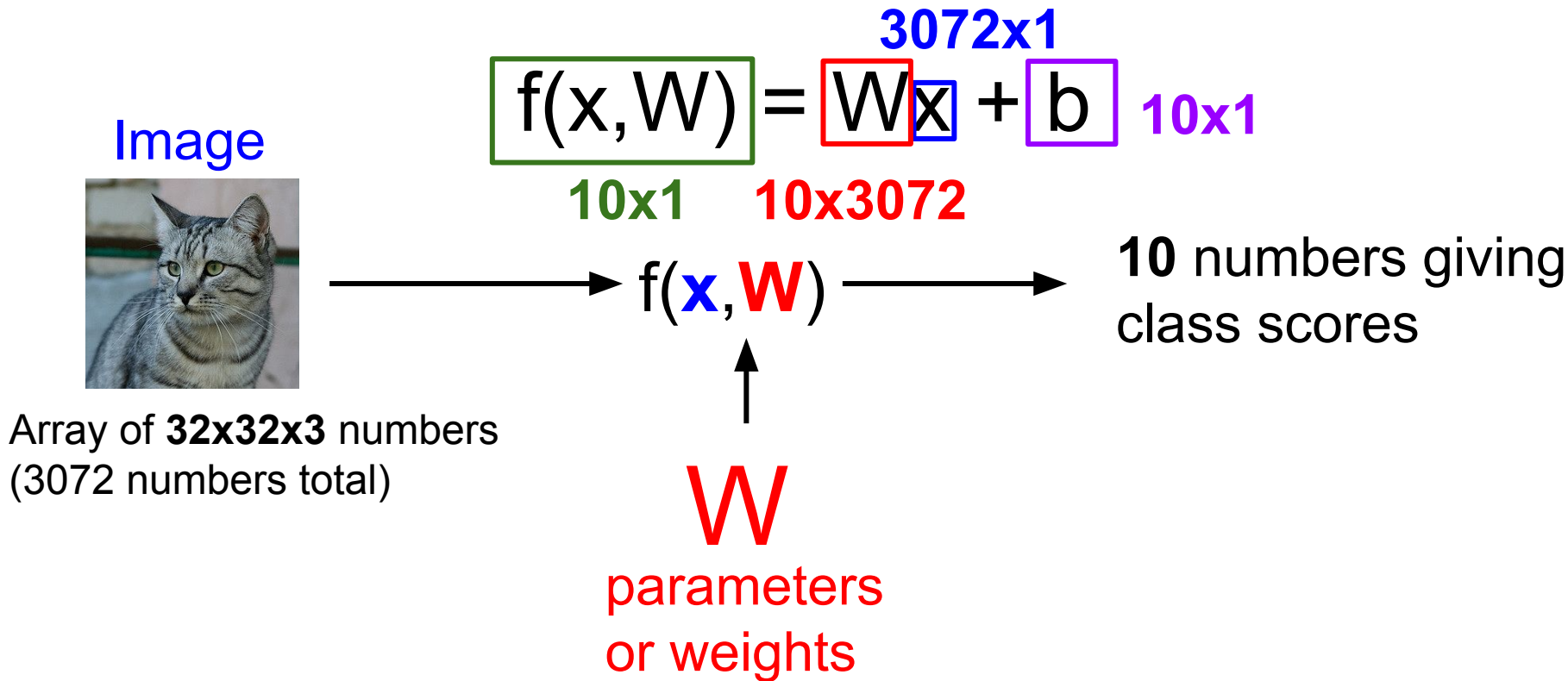

Neural Network

Linear
classifiers



[This image](#) is [CC0 1.0](#) public domain

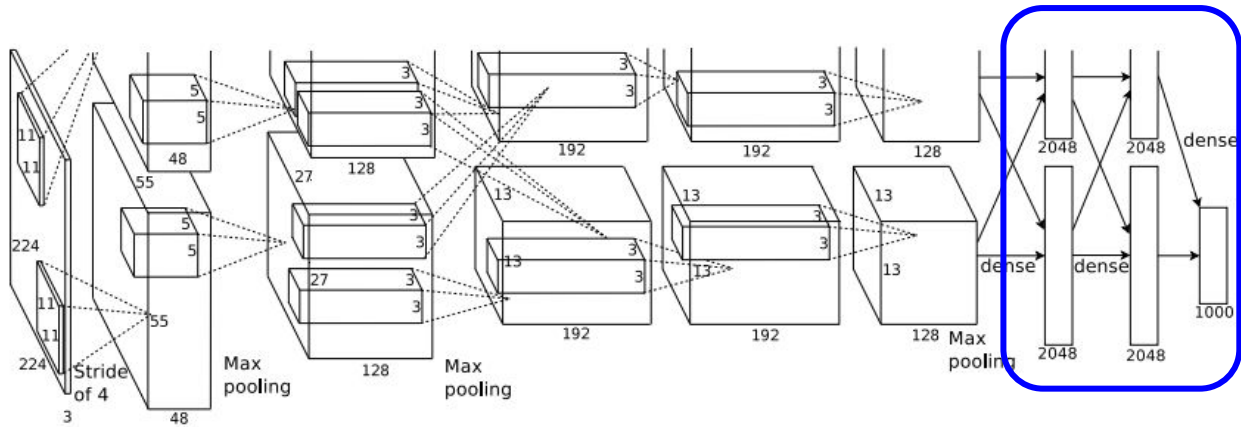

[Krizhevsky et al. 2012]

Linear layers

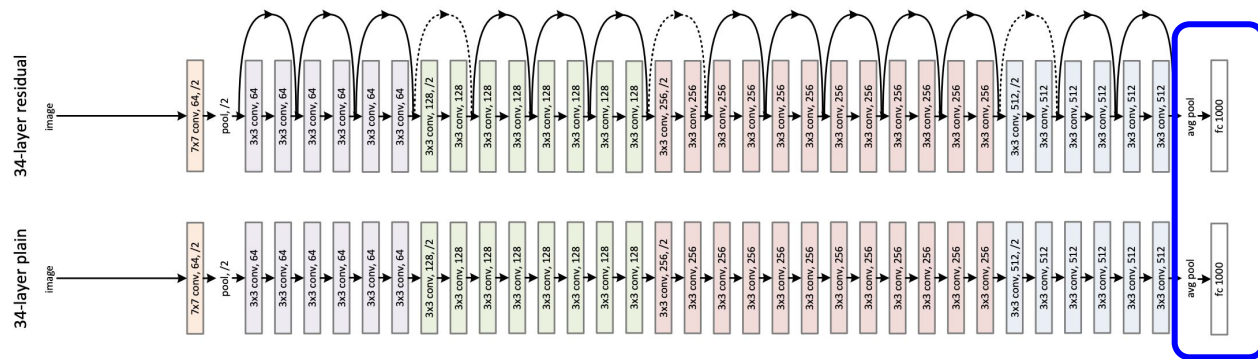

[He et al. 2015]

Linear layers

Recall CIFAR10

airplane

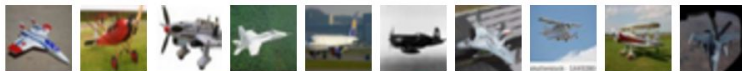

automobile



bird

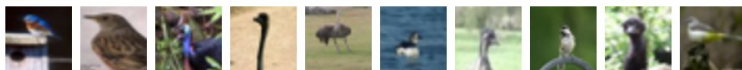

cat

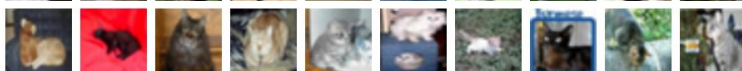

deer

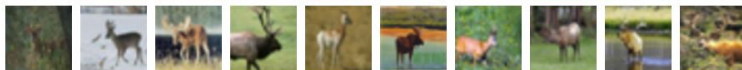

dog



frog



horse



ship



truck

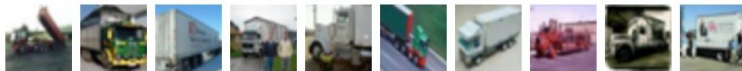

50,000 training images
each image is **32x32x3**

10,000 test images.

Example with an image with 4 pixels, and 3 classes (cat/dog/ship)

Flatten tensors into a vector

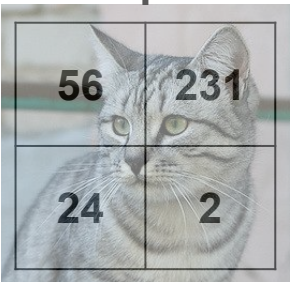

Input image



Example with an image with 4 pixels, and 3 classes (cat/dog/ship)

Algebraic Viewpoint

Flatten tensors into a vector

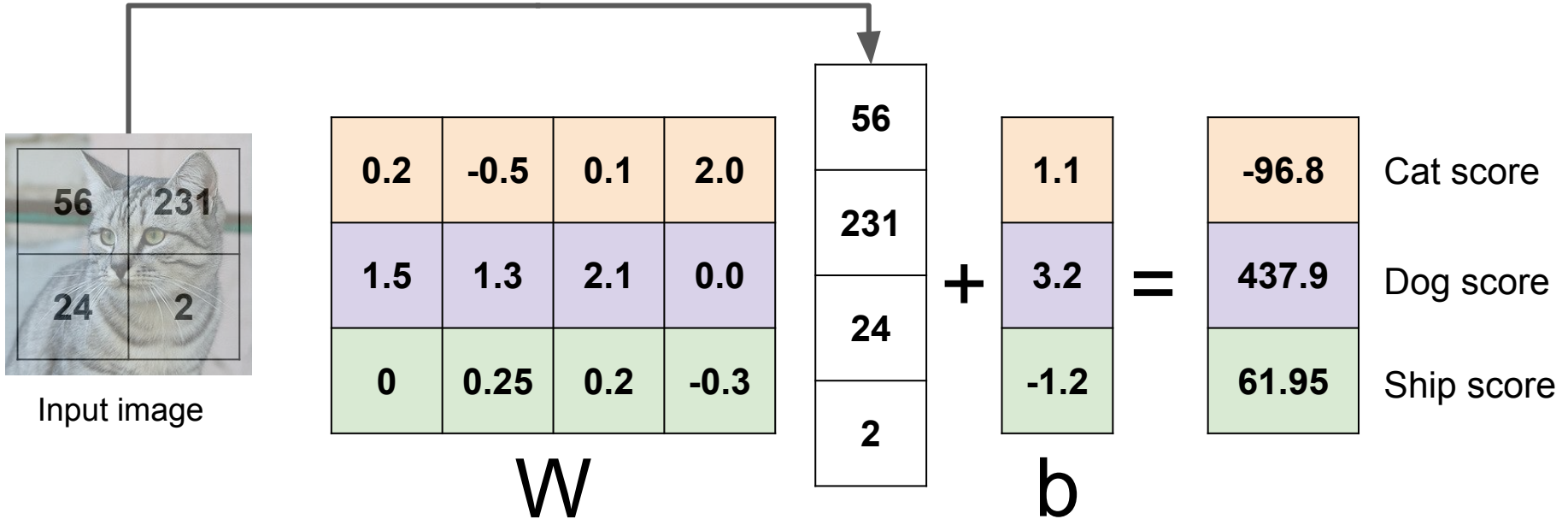

Interpreting a Linear Classifier

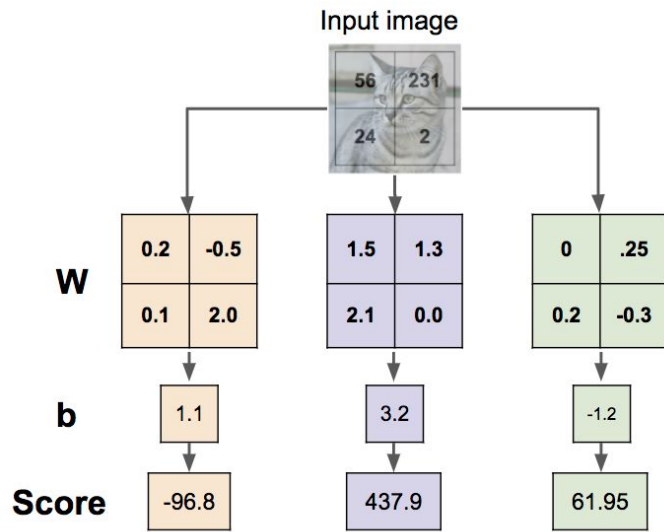
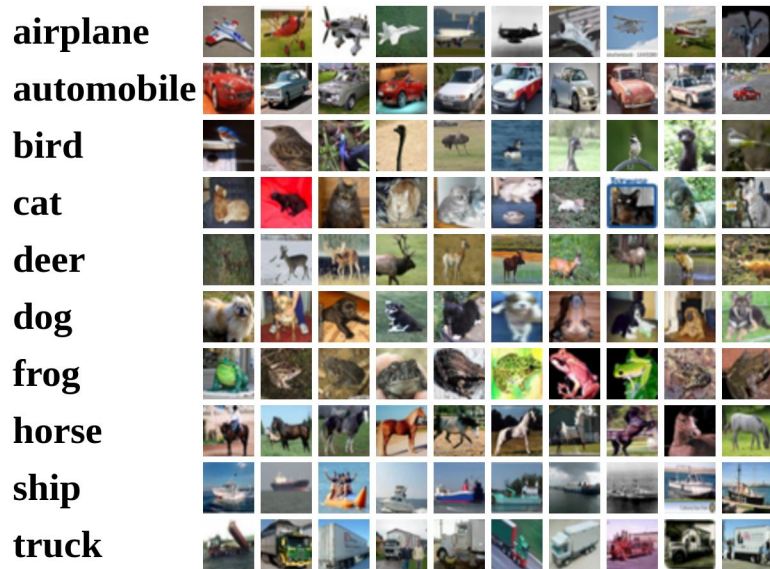

Interpreting a Linear Classifier: Visual Viewpoint

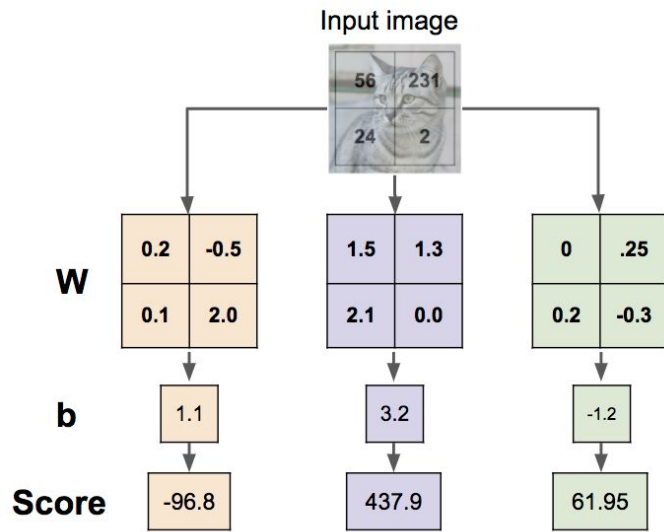

Interpreting a Linear Classifier: Geometric Viewpoint

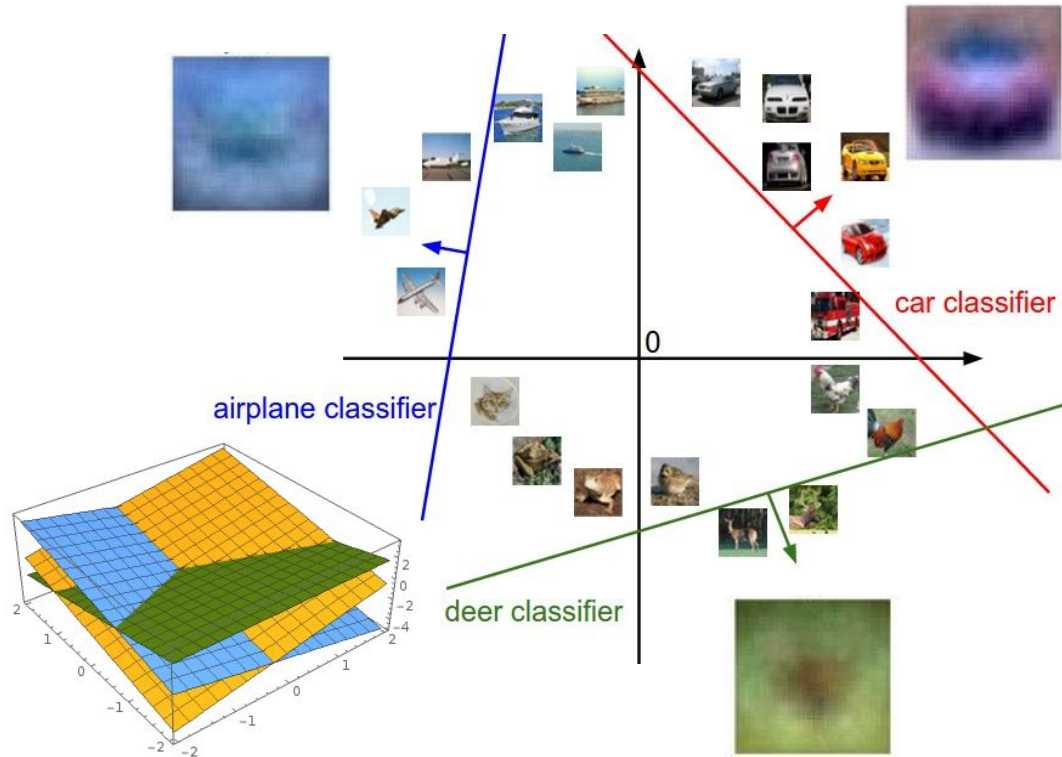

$$f(x, W) = Wx + b$$



Array of **32x32x3** numbers
(3072 numbers total)

Plot created using [Wolfram Cloud](https://www.wolframcloud.com/)

Cat image by [Nikita](#) is licensed under [CC-BY 2.0](#)

Hard cases for a linear classifier

Class 1:

First and third quadrants

Class 2:

Second and fourth quadrants

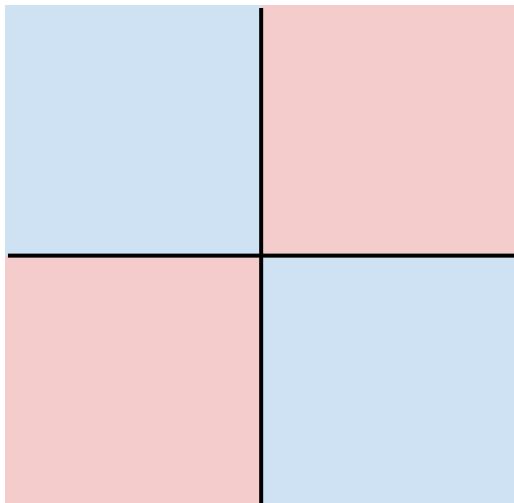

Class 1:

$1 \leq \text{L2 norm} \leq 2$

Class 2:

Everything else

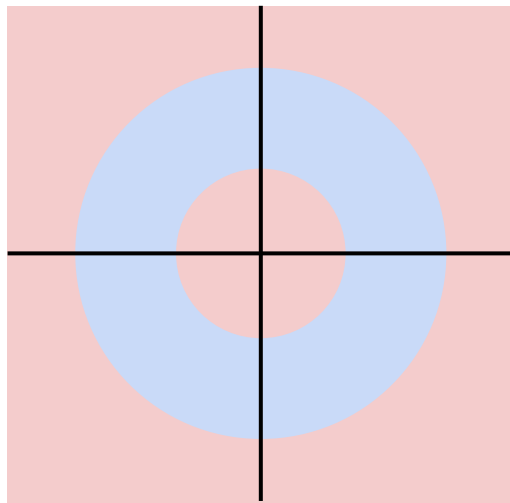

Class 1:

Three modes

Class 2:

Everything else

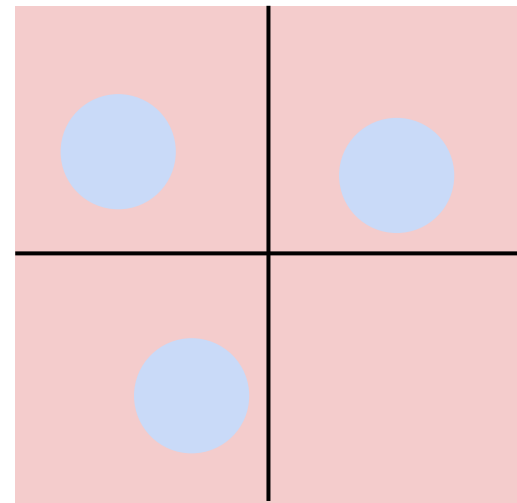

Linear Classifier – Choose a good W



airplane	-3.45	-0.51	3.42
automobile	-8.87	6.04	4.64
bird	0.09	5.31	2.65
cat	2.9	-4.22	5.1
deer	4.48	-4.19	2.64
dog	8.02	3.58	5.55
frog	3.78	4.49	-4.34
horse	1.06	-4.37	-1.5
ship	-0.36	-2.09	-4.79
truck	-0.72	-2.93	6.14

TODO:

1. Define a **loss function** that quantifies our unhappiness with the scores across the training data.
2. Come up with a way of efficiently finding the parameters that minimize the loss function. (**optimization**)

[Cat image](#) by [Nikita](#) is licensed under [CC-BY-2.0](#); [Car image](#) is [CC0 1.0](#) public domain; [Frog image](#) is in the public domain

Suppose: 3 training examples, 3 classes.

With some W the scores $f(x, W) = Wx$ are:

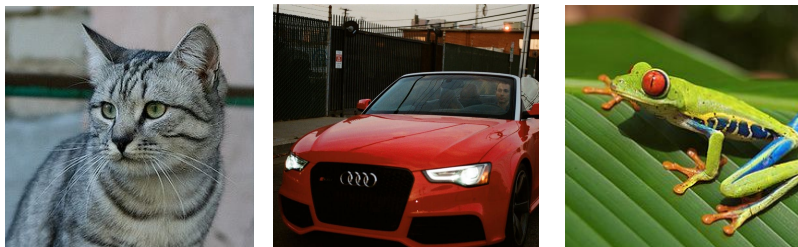

cat	3.2	1.3	2.2
car	5.1	4.9	2.5
frog	-1.7	2.0	-3.1

Suppose: 3 training examples, 3 classes.
With some W the scores $f(x, W) = Wx$ are:

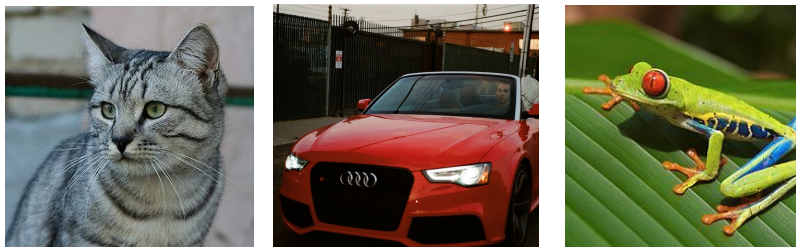

cat	3.2	1.3	2.2
car	5.1	4.9	2.5
frog	-1.7	2.0	-3.1

A **loss function** tells how good our current classifier is

Suppose: 3 training examples, 3 classes.
With some W the scores $f(x, W) = Wx$ are:

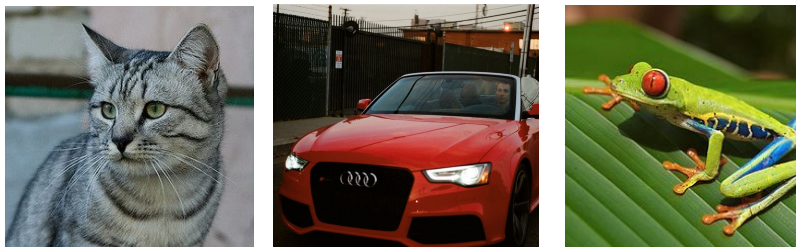

cat	3.2	1.3	2.2
car	5.1	4.9	2.5
frog	-1.7	2.0	-3.1

A **loss function** tells how good our current classifier is

Given a dataset of examples

$$\{(x_i, y_i)\}_{i=1}^N$$

Where x_i is image and
 y_i is (integer) label

Suppose: 3 training examples, 3 classes.
With some W the scores $f(x, W) = Wx$ are:

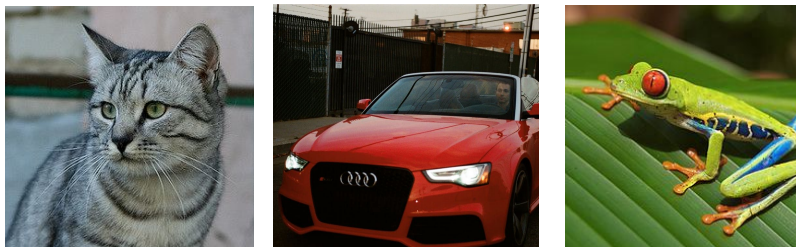

cat	3.2	1.3	2.2
car	5.1	4.9	2.5
frog	-1.7	2.0	-3.1

A **loss function** tells how good our current classifier is

Given a dataset of examples

$$\{(x_i, y_i)\}_{i=1}^N$$

Where x_i is image and
 y_i is (integer) label

Loss over the dataset is a
average of loss over examples:

$$L = \frac{1}{N} \sum_i L_i(f(x_i, W), y_i)$$

Suppose: 3 training examples, 3 classes.
 With some W the scores $f(x, W) = Wx$ are:

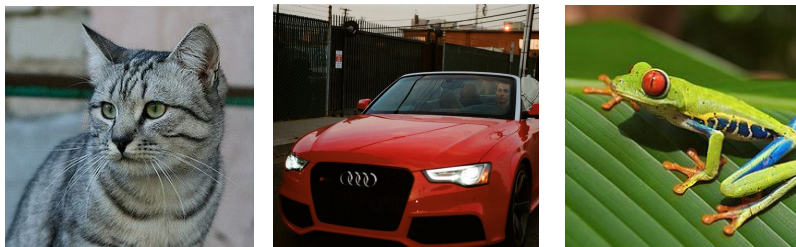

cat	3.2	1.3	2.2
car	5.1	4.9	2.5
frog	-1.7	2.0	-3.1

Multiclass SVM loss:

Given an example (x_i, y_i)
 where x_i is the image and
 where y_i is the (integer) label,

and using the shorthand for the
 scores vector: $s = f(x_i, W)$

the SVM loss has the form:

$$L_i = \sum_{j \neq y_i} \begin{cases} 0 & \text{if } s_{y_i} \geq s_j + 1 \\ s_j - s_{y_i} + 1 & \text{otherwise} \end{cases}$$

$$= \sum_{j \neq y_i} \max(0, s_j - s_{y_i} + 1)$$

Suppose: 3 training examples, 3 classes.
 With some W the scores $f(x, W) = Wx$ are:

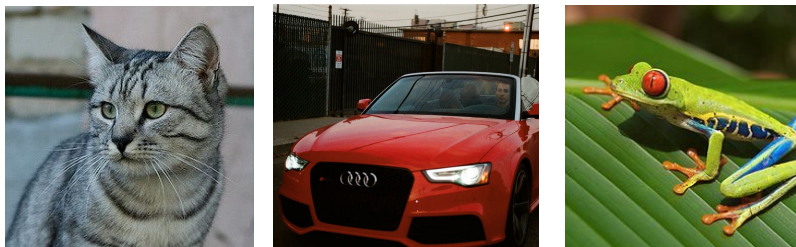

cat	3.2	1.3	2.2
car	5.1	4.9	2.5
frog	-1.7	2.0	-3.1

Interpreting Multiclass SVM loss:

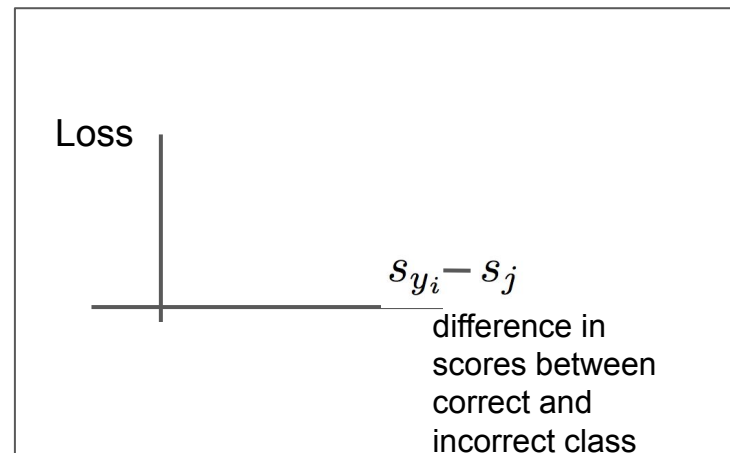

$$L_i = \sum_{j \neq y_i} \begin{cases} 0 & \text{if } s_{y_i} \geq s_j + 1 \\ s_j - s_{y_i} + 1 & \text{otherwise} \end{cases}$$

$$= \sum_{j \neq y_i} \max(0, s_j - s_{y_i} + 1)$$

Suppose: 3 training examples, 3 classes.
 With some W the scores $f(x, W) = Wx$ are:

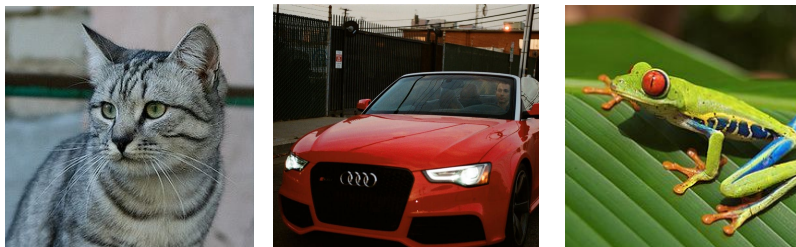

cat	3.2	1.3	2.2
car	5.1	4.9	2.5
frog	-1.7	2.0	-3.1

Interpreting Multiclass SVM loss:

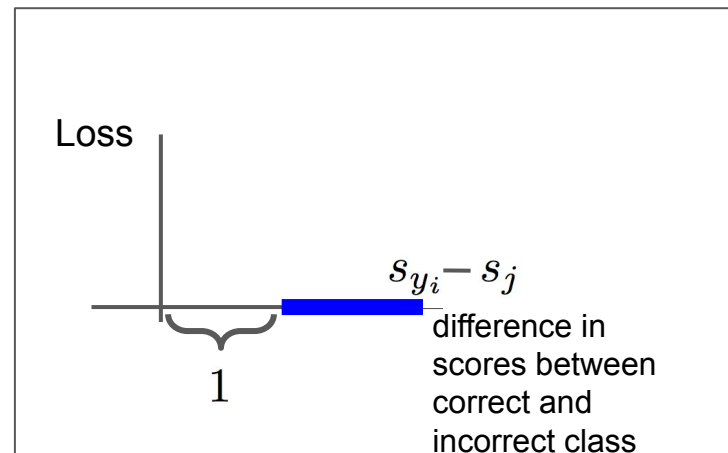

$$L_i = \sum_{j \neq y_i} \begin{cases} 0 & \text{if } s_{y_i} \geq s_j + 1 \\ s_j - s_{y_i} + 1 & \text{otherwise} \end{cases}$$

$$= \sum_{j \neq y_i} \max(0, s_j - s_{y_i} + 1)$$

Suppose: 3 training examples, 3 classes.
 With some W the scores $f(x, W) = Wx$ are:

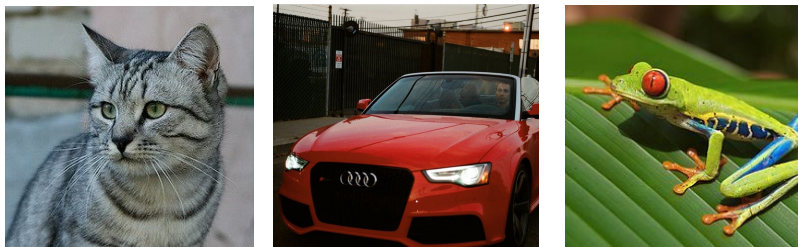

cat	3.2	1.3	2.2
car	5.1	4.9	2.5
frog	-1.7	2.0	-3.1

Interpreting Multiclass SVM loss:

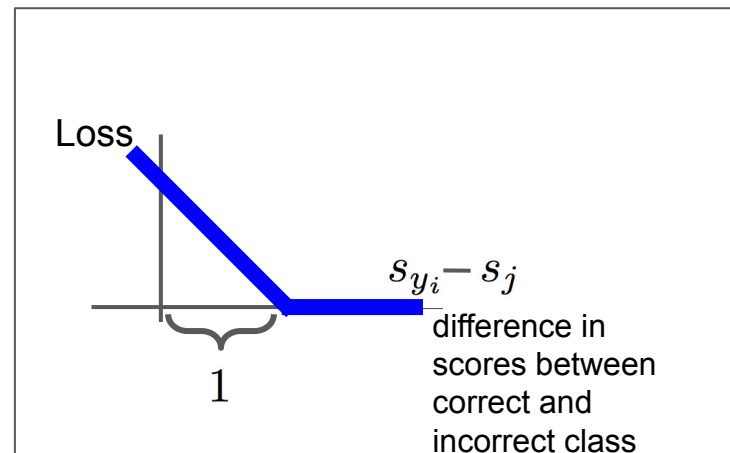

$$L_i = \sum_{j \neq y_i} \begin{cases} 0 & \text{if } s_{y_i} \geq s_j + 1 \\ s_j - s_{y_i} + 1 & \text{otherwise} \end{cases}$$

$$= \sum_{j \neq y_i} \max(0, s_j - s_{y_i} + 1)$$

Suppose: 3 training examples, 3 classes.
With some W the scores $f(x, W) = Wx$ are:

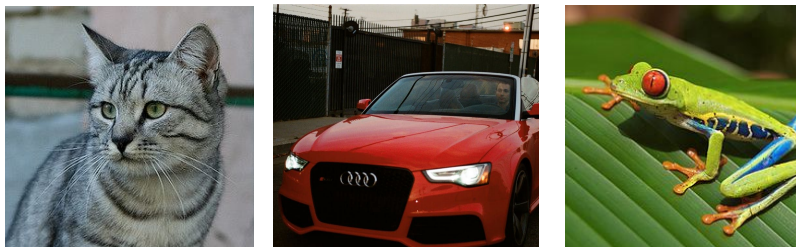

cat	3.2	1.3	2.2
car	5.1	4.9	2.5
frog	-1.7	2.0	-3.1

Multiclass SVM loss:

Given an example (x_i, y_i)
where x_i is the image and
where y_i is the (integer) label,

and using the shorthand for the
scores vector: $s = f(x_i, W)$

the SVM loss has the form:

$$L_i = \sum_{j \neq y_i} \max(0, s_j - s_{y_i} + 1)$$

Suppose: 3 training examples, 3 classes.
 With some W the scores $f(x, W) = Wx$ are:

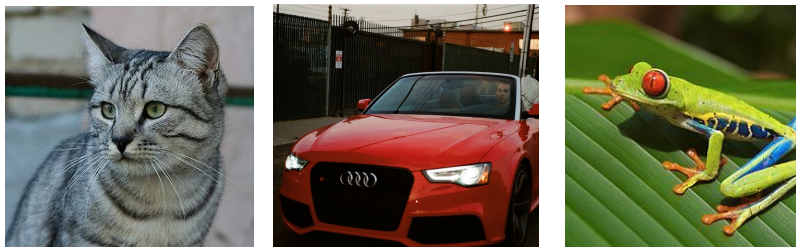

cat	3.2	1.3	2.2
car	5.1	4.9	2.5
frog	-1.7	2.0	-3.1
Losses:	2.9		

Multiclass SVM loss:

Given an example (x_i, y_i)
 where x_i is the image and
 where y_i is the (integer) label,

and using the shorthand for the
 scores vector: $s = f(x_i, W)$

the SVM loss has the form:

$$\begin{aligned}
 L_i &= \sum_{j \neq y_i} \max(0, s_j - s_{y_i} + 1) \\
 &= \max(0, 5.1 - 3.2 + 1) \\
 &\quad + \max(0, -1.7 - 3.2 + 1) \\
 &= \max(0, 2.9) + \max(0, -3.9) \\
 &= 2.9 + 0 \\
 &= 2.9
 \end{aligned}$$

Suppose: 3 training examples, 3 classes.
 With some W the scores $f(x, W) = Wx$ are:

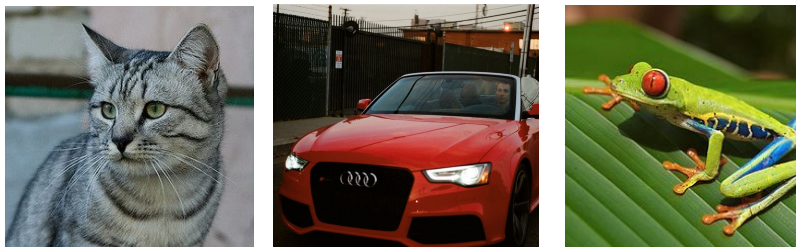

cat	3.2	1.3	2.2
car	5.1	4.9	2.5
frog	-1.7	2.0	-3.1
Losses:	2.9	0	

Multiclass SVM loss:

Given an example (x_i, y_i)
 where x_i is the image and
 where y_i is the (integer) label,

and using the shorthand for the
 scores vector: $s = f(x_i, W)$

the SVM loss has the form:

$$\begin{aligned}
 L_i &= \sum_{j \neq y_i} \max(0, s_j - s_{y_i} + 1) \\
 &= \max(0, 1.3 - 4.9 + 1) \\
 &\quad + \max(0, 2.0 - 4.9 + 1) \\
 &= \max(0, -2.6) + \max(0, -1.9) \\
 &= 0 + 0 \\
 &= 0
 \end{aligned}$$

Suppose: 3 training examples, 3 classes.
 With some W the scores $f(x, W) = Wx$ are:

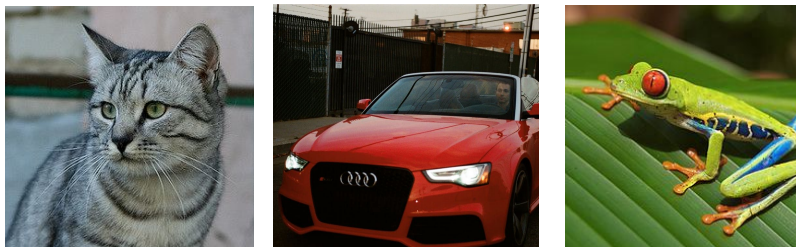

cat	3.2	1.3	2.2
car	5.1	4.9	2.5
frog	-1.7	2.0	-3.1
Losses:	2.9	0	12.9

Multiclass SVM loss:

Given an example (x_i, y_i)
 where x_i is the image and
 where y_i is the (integer) label,

and using the shorthand for the
 scores vector: $s = f(x_i, W)$

the SVM loss has the form:

$$\begin{aligned}
 L_i &= \sum_{j \neq y_i} \max(0, s_j - s_{y_i} + 1) \\
 &= \max(0, 2.2 - (-3.1) + 1) \\
 &\quad + \max(0, 2.5 - (-3.1) + 1) \\
 &= \max(0, 6.3) + \max(0, 6.6) \\
 &= 6.3 + 6.6 \\
 &= 12.9
 \end{aligned}$$

Suppose: 3 training examples, 3 classes.
 With some W the scores $f(x, W) = Wx$ are:

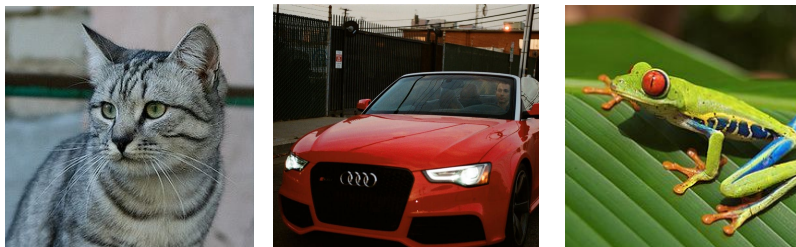

cat	3.2	1.3	2.2
car	5.1	4.9	2.5
frog	-1.7	2.0	-3.1
Losses:	2.9	0	12.9

Multiclass SVM loss:

Given an example (x_i, y_i)
 where x_i is the image and
 where y_i is the (integer) label,

and using the shorthand for the
 scores vector: $s = f(x_i, W)$

the SVM loss has the form:

$$L_i = \sum_{j \neq y_i} \max(0, s_j - s_{y_i} + 1)$$

Loss over full dataset is average:

$$L = \frac{1}{N} \sum_{i=1}^N L_i$$

$$L = (2.9 + 0 + 12.9)/3 \\ = \mathbf{5.27}$$

Suppose: 3 training examples, 3 classes.
With some W the scores $f(x, W) = Wx$ are:

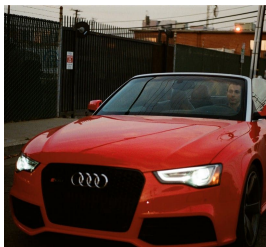

cat	1.3
car	4.9
frog	2.0
Losses:	0

Multiclass SVM loss:

$$L_i = \sum_{j \neq y_i} \max(0, s_j - s_{y_i} + 1)$$

Q1: What happens to loss if car scores decrease by 0.5 for this training example?

Q2: what is the min/max possible SVM loss L_i ?

Q3: At initialization W is small so all $s \approx 0$. What is the loss L_i , assuming N examples and C classes?

Suppose: 3 training examples, 3 classes.
 With some W the scores $f(x, W) = Wx$ are:

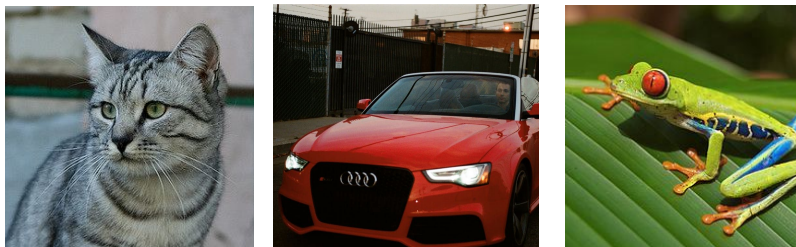

cat	3.2	1.3	2.2
car	5.1	4.9	2.5
frog	-1.7	2.0	-3.1
Losses:	2.9	0	12.9

Multiclass SVM loss:

Given an example (x_i, y_i)
 where x_i is the image and
 where y_i is the (integer) label,

and using the shorthand for the
 scores vector: $s = f(x_i, W)$

the SVM loss has the form:

$$L_i = \sum_{j \neq y_i} \max(0, s_j - s_{y_i} + 1)$$

Q4: What if the sum
 was over all classes?
 (including $j = y_i$)

Suppose: 3 training examples, 3 classes.
 With some W the scores $f(x, W) = Wx$ are:

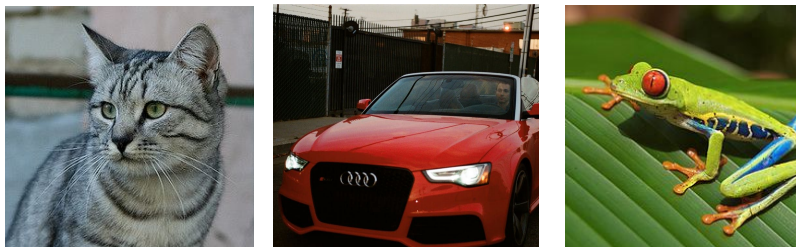

cat	3.2	1.3	2.2
car	5.1	4.9	2.5
frog	-1.7	2.0	-3.1
Losses:	2.9	0	12.9

Multiclass SVM loss:

Given an example (x_i, y_i)
 where x_i is the image and
 where y_i is the (integer) label,

and using the shorthand for the
 scores vector: $s = f(x_i, W)$

the SVM loss has the form:

$$L_i = \sum_{j \neq y_i} \max(0, s_j - s_{y_i} + 1)$$

Q5: What if we used
 mean instead of
 sum?

Suppose: 3 training examples, 3 classes.
 With some W the scores $f(x, W) = Wx$ are:

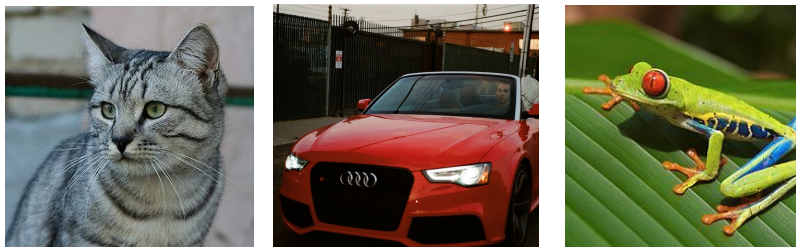

cat	3.2	1.3	2.2
car	5.1	4.9	2.5
frog	-1.7	2.0	-3.1
Losses:	2.9	0	12.9

Multiclass SVM loss:

Given an example (x_i, y_i)
 where x_i is the image and
 where y_i is the (integer) label,

and using the shorthand for the
 scores vector: $s = f(x_i, W)$

the SVM loss has the form:

$$L_i = \sum_{j \neq y_i} \max(0, s_j - s_{y_i} + 1)$$

Q6: What if we used

$$L_i = \sum_{j \neq y_i} \max(0, s_j - s_{y_i} + 1)^2$$

Suppose: 3 training examples, 3 classes.
 With some W the scores $f(x, W) = Wx$ are:

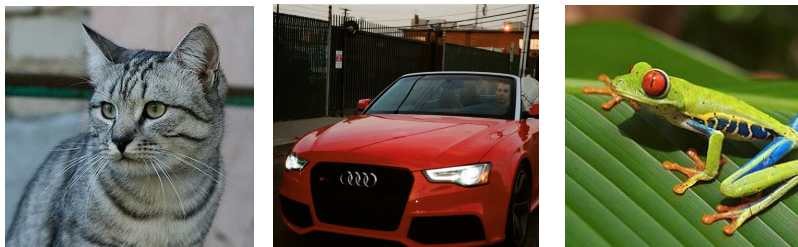

cat	3.2	1.3	2.2
car	5.1	4.9	2.5
frog	-1.7	2.0	-3.1
Losses:	2.9	0	12.9

Multiclass SVM loss:

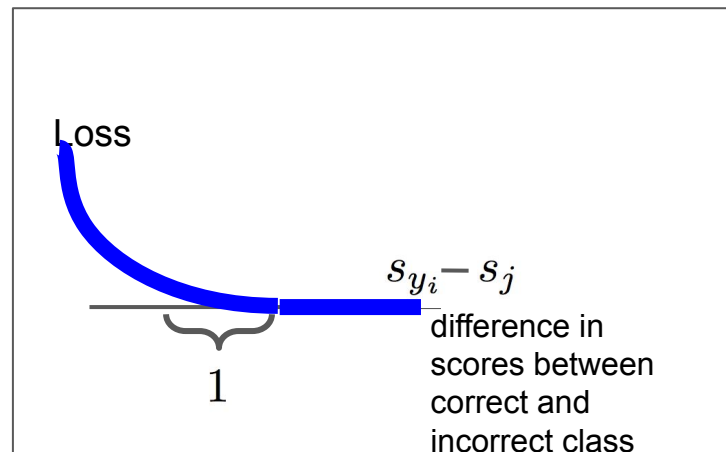

Q6: What if we used

$$L_i = \sum_{j \neq y_i} \max(0, s_j - s_{y_i} + 1)^2$$

Multiclass SVM Loss: Example code

$$L_i = \sum_{j \neq y_i} \max(0, s_j - s_{y_i} + 1)$$

```
def L_i_vectorized(x, y, W):  
    scores = W.dot(x)  
    margins = np.maximum(0, scores - scores[y] + 1)  
    margins[y] = 0  
    loss_i = np.sum(margins)  
    return loss_i
```

First calculate scores
Then calculate the margins $s_j - s_{y_i} + 1$
only sum j is not y_i , so when $j = y_i$, set to zero.
sum across all j

Softmax classifier

Softmax Classifier (Multinomial Logistic Regression)

Want to interpret raw classifier scores as **probabilities**



cat	3.2
car	5.1
frog	-1.7

Softmax Classifier (Multinomial Logistic Regression)



Want to interpret raw classifier scores as **probabilities**

$$s = f(x_i; W)$$

$$P(Y = k | X = x_i) = \frac{e^{s_k}}{\sum_j e^{s_j}}$$

Softmax
Function

cat	3.2
car	5.1
frog	-1.7

Softmax Classifier (Multinomial Logistic Regression)



Want to interpret raw classifier scores as **probabilities**

$$s = f(x_i; W)$$

$$P(Y = k | X = x_i) = \frac{e^{s_k}}{\sum_j e^{s_j}}$$

Softmax
Function

Probabilities
must be ≥ 0

cat	3.2
car	5.1
frog	-1.7

exp

	→	24.5
		164.0
		0.18

unnormalized
probabilities

Softmax Classifier (Multinomial Logistic Regression)



Want to interpret raw classifier scores as **probabilities**

$$s = f(x_i; W)$$

$$P(Y = k | X = x_i) = \frac{e^{s_k}}{\sum_j e^{s_j}}$$

Softmax
Function

Probabilities
must be ≥ 0

Probabilities
must sum to 1

cat	3.2
car	5.1
frog	-1.7

exp

24.5
164.0
0.18

normalize

0.13
0.87
0.00

unnormalized
probabilities

probabilities

Softmax Classifier (Multinomial Logistic Regression)



Want to interpret raw classifier scores as **probabilities**

$$s = f(x_i; W)$$

$$P(Y = k | X = x_i) = \frac{e^{s_k}}{\sum_j e^{s_j}}$$

Softmax
Function

Probabilities
must be ≥ 0

Probabilities
must sum to 1

cat
car
frog

3.2
5.1
-1.7

Unnormalized
log-probabilities / logits

exp

24.5
164.0
0.18

unnormalized
probabilities

normalize

0.13
0.87
0.00

probabilities

Softmax Classifier (Multinomial Logistic Regression)



Want to interpret raw classifier scores as **probabilities**

$$s = f(x_i; W)$$

$$P(Y = k | X = x_i) = \frac{e^{s_k}}{\sum_j e^{s_j}} \quad \text{Softmax Function}$$

Probabilities
must be ≥ 0

Probabilities
must sum to 1

$$L_i = -\log P(Y = y_i | X = x_i)$$

cat
car
frog

3.2
5.1
-1.7

Unnormalized
log-probabilities / logits

exp

24.5
164.0
0.18

unnormalized
probabilities

normalize

0.13
0.87
0.00

probabilities

$$\rightarrow L_i = -\log(0.13) = 2.04$$

Softmax Classifier (Multinomial Logistic Regression)



Want to interpret raw classifier scores as **probabilities**

$$s = f(x_i; W)$$

$$P(Y = k | X = x_i) = \frac{e^{s_k}}{\sum_j e^{s_j}} \quad \text{Softmax Function}$$

Probabilities
must be ≥ 0

Probabilities
must sum to 1

$$L_i = -\log P(Y = y_i | X = x_i)$$

cat
car
frog

3.2
5.1
-1.7

Unnormalized
log-probabilities / logits

exp

24.5
164.0
0.18

unnormalized
probabilities

normalize

0.13
0.87
0.00

probabilities

$$\rightarrow L_i = -\log(0.13) = 2.04$$

Maximum Likelihood Estimation
Choose weights to maximize the likelihood of the observed data
(See CS 229 for details)

Softmax Classifier (Multinomial Logistic Regression)



Want to interpret raw classifier scores as **probabilities**

$$s = f(x_i; W)$$

$$P(Y = k | X = x_i) = \frac{e^{s_k}}{\sum_j e^{s_j}}$$

Softmax
Function

Probabilities
must be ≥ 0

Probabilities
must sum to 1

$$L_i = -\log P(Y = y_i | X = x_i)$$

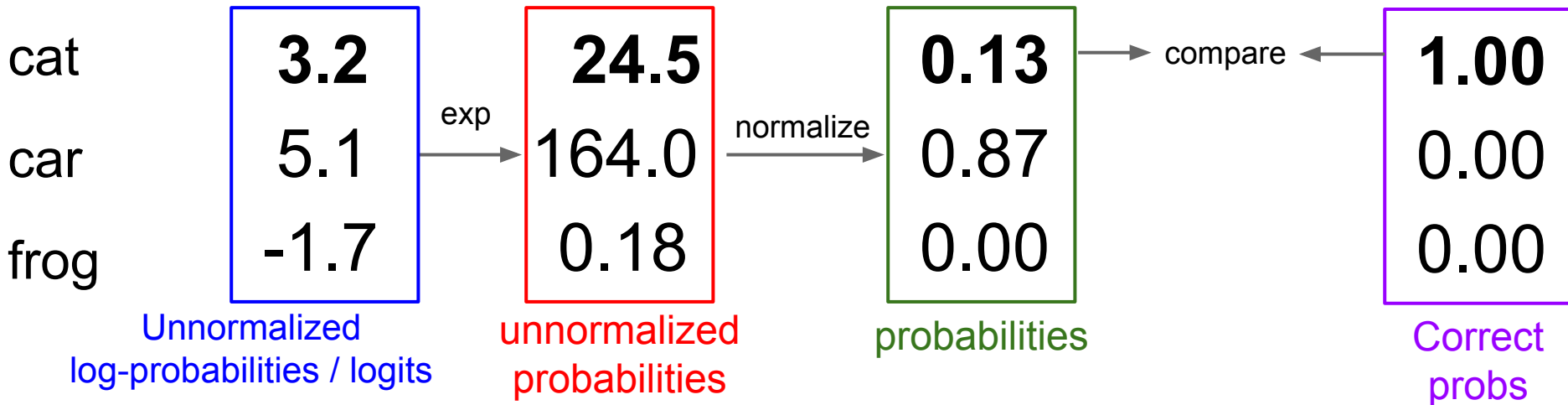

Softmax Classifier (Multinomial Logistic Regression)



Want to interpret raw classifier scores as **probabilities**

$$s = f(x_i; W)$$

$$P(Y = k | X = x_i) = \frac{e^{s_k}}{\sum_j e^{s_j}}$$

Softmax Function

Probabilities must be ≥ 0

Probabilities must sum to 1

$$L_i = -\log P(Y = y_i | X = x_i)$$

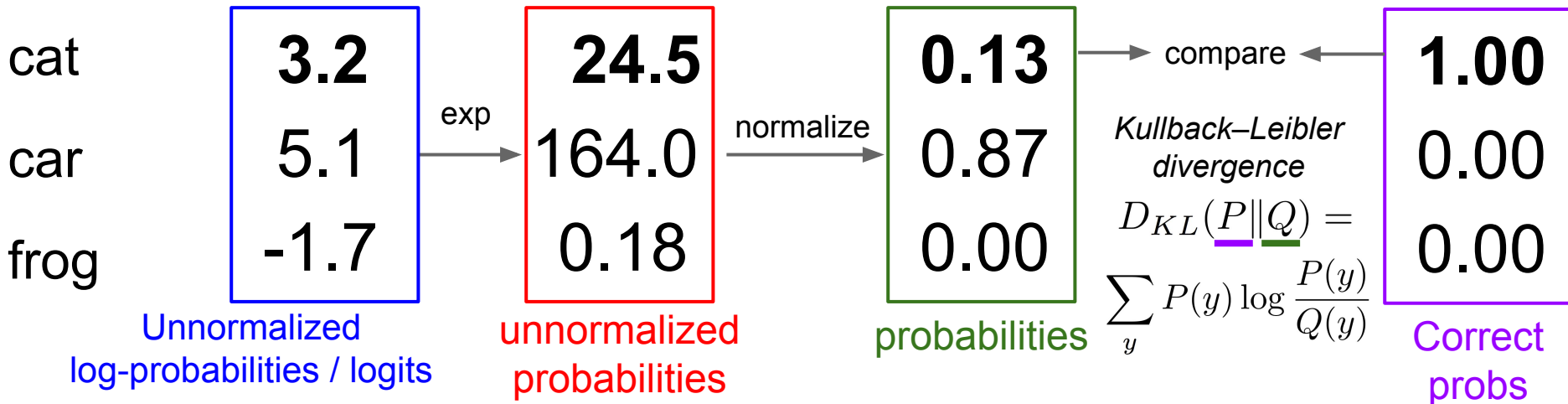

Softmax Classifier (Multinomial Logistic Regression)



Want to interpret raw classifier scores as **probabilities**

$$s = f(x_i; W)$$

$$P(Y = k | X = x_i) = \frac{e^{s_k}}{\sum_j e^{s_j}}$$
 Softmax Function

Probabilities must be ≥ 0

Probabilities must sum to 1

$$L_i = -\log P(Y = y_i | X = x_i)$$

cat
car
frog

3.2
5.1
-1.7

Unnormalized log-probabilities / logits

exp

24.5
164.0
0.18

unnormalized probabilities

normalize

0.13
0.87
0.00

probabilities

compare

Cross Entropy

$$H(\underline{P}, \underline{Q}) = H(p) + D_{KL}(P \| Q)$$

1.00
0.00
0.00

Correct probs

Softmax Classifier (Multinomial Logistic Regression)



Want to interpret raw classifier scores as **probabilities**

$$s = f(x_i; W)$$

$$P(Y = k | X = x_i) = \frac{e^{s_k}}{\sum_j e^{s_j}} \quad \text{Softmax Function}$$

Maximize probability of correct class

Putting it all together:

$$L_i = -\log P(Y = y_i | X = x_i)$$

$$L_i = -\log\left(\frac{e^{s_{y_i}}}{\sum_j e^{s_j}}\right)$$

cat	3.2
car	5.1
frog	-1.7

Softmax Classifier (Multinomial Logistic Regression)



Want to interpret raw classifier scores as **probabilities**

$$s = f(x_i; W)$$

$$P(Y = k | X = x_i) = \frac{e^{s_k}}{\sum_j e^{s_j}} \quad \text{Softmax Function}$$

Maximize probability of correct class

Putting it all together:

$$L_i = -\log P(Y = y_i | X = x_i)$$

$$L_i = -\log\left(\frac{e^{s_{y_i}}}{\sum_j e^{s_j}}\right)$$

cat **3.2**

car **5.1**

frog **-1.7**

Q1: What is the min/max possible softmax loss L_i ?

Q2: At initialization all s_j will be approximately equal; what is the softmax loss L_i , assuming C classes?

Softmax Classifier (Multinomial Logistic Regression)



Want to interpret raw classifier scores as **probabilities**

$$s = f(x_i; W)$$

$$P(Y = k | X = x_i) = \frac{e^{s_k}}{\sum_j e^{s_j}} \quad \text{Softmax Function}$$

Maximize probability of correct class

Putting it all together:

$$L_i = -\log P(Y = y_i | X = x_i)$$

$$L_i = -\log\left(\frac{e^{s_{y_i}}}{\sum_j e^{s_j}}\right)$$

cat **3.2**

car **5.1**

frog **-1.7**

Q2: At initialization all s will be approximately equal; what is the loss?

A: $-\log(1/C) = \log(C)$,

If $C = 10$, then $L_i = \log(10) \approx 2.3$

Softmax vs. SVM

matrix multiply + bias offset

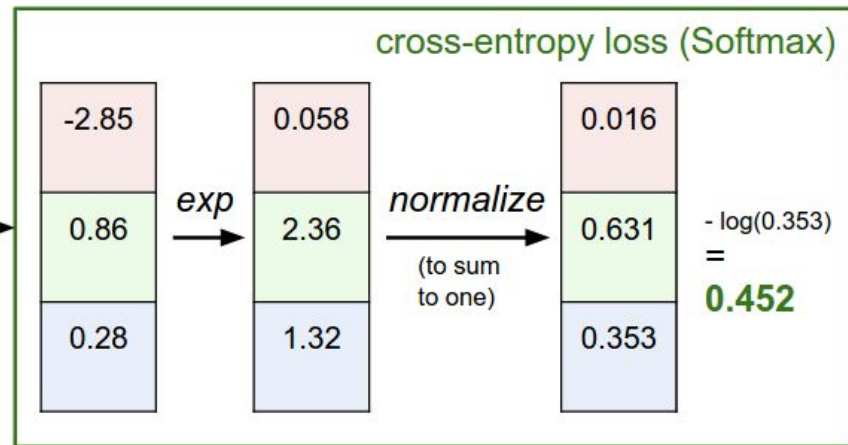
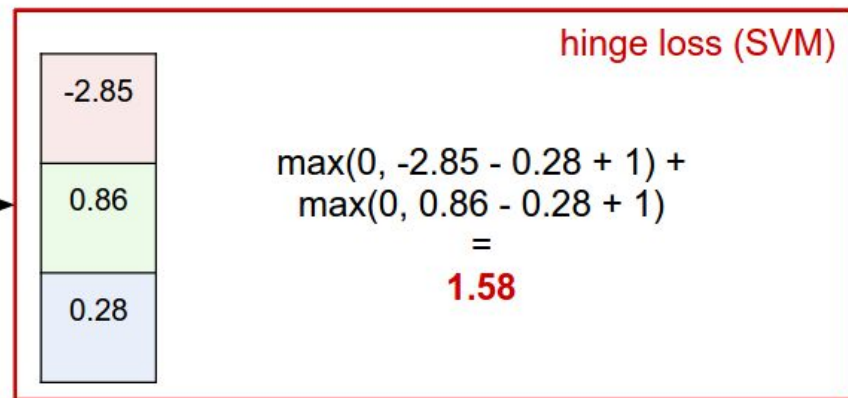
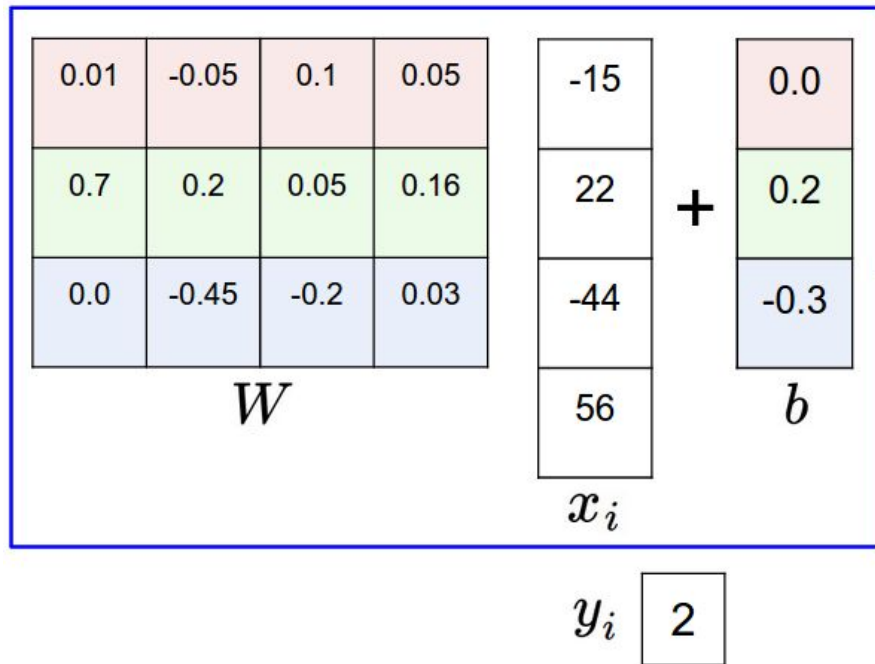

Softmax vs. SVM

$$L_i = -\log\left(\frac{e^{s_{y_i}}}{\sum_j e^{s_j}}\right)$$

$$L_i = \sum_{j \neq y_i} \max(0, s_j - s_{y_i} + 1)$$

Softmax vs. SVM

$$L_i = -\log\left(\frac{e^{s_{y_i}}}{\sum_j e^{s_j}}\right)$$

$$L_i = \sum_{j \neq y_i} \max(0, s_j - s_{y_i} + 1)$$

assume scores:

[10, -2, 3]

[10, 9, 9]

[10, -100, -100]

and $y_i = 0$

Q: What is the **softmax loss** and the **SVM loss**?

Softmax vs. SVM

$$L_i = -\log\left(\frac{e^{s_{y_i}}}{\sum_j e^{s_j}}\right)$$

$$L_i = \sum_{j \neq y_i} \max(0, s_j - s_{y_i} + 1)$$

assume scores:

[20, -2, 3]

[20, 9, 9]

[20, -100, -100]

and $y_i = 0$

Q: What is the **softmax loss** and the **SVM loss** if I double the **correct class score from 10 -> 20**?

Coming up:

- Regularization
- Optimization

$$f(x, W) = Wx + b$$

